



Type: Y+U  
bwnr: 295

Type: Z45+  
bwnr: 296

Type: Z45+  
bwnr: 297

Type: Z45+  
bwnr: 298

Type: Z45+  
bwnr: 299

Type: Z45+  
bwnr: 300

Type: Y+U  
bwnr: 301

Vorgevel

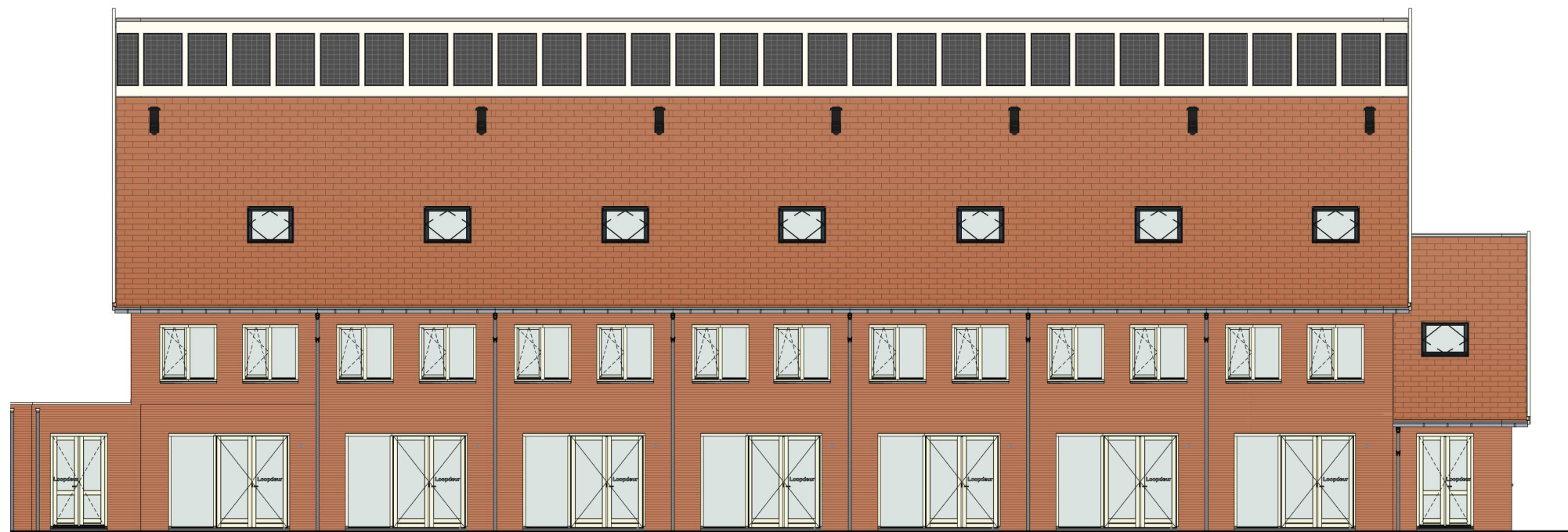

Type: Y+U  
bwnr: 301

Type: Z45+  
bwnr: 300

Type: Z45+  
bwnr: 299

Type: Z45+  
bwnr: 298

Type: Z45+  
bwnr: 297

Type: Z45+  
bwnr: 296

Type: Y+U  
bwnr: 295

Achtergevel

ALLEMAAL  
YIELEYAAL

Tekening: Gevels blok L4

Woningtype: Z45+, Y+U

Bouwnummer: 295 t/m 301

Bladnummer: VT-L4-00a

Schaal: 1:150

Datum: 30-01-2024



Type: Y+U  
Bouwnummer: 295

Linker zijgevel



Type: Y+U  
Bouwnummer: 301

Rechter zijgevel

**ALLEMAAL  
YIELEYAAL**

Tekening: Zijgevels blok L4

Woningtype: Z45+, Y+U

Bouwnummer: 295 t/m 301

Bladnummer: VT-L4-00b

Schaal: 1:100

Datum: 30-01-2024

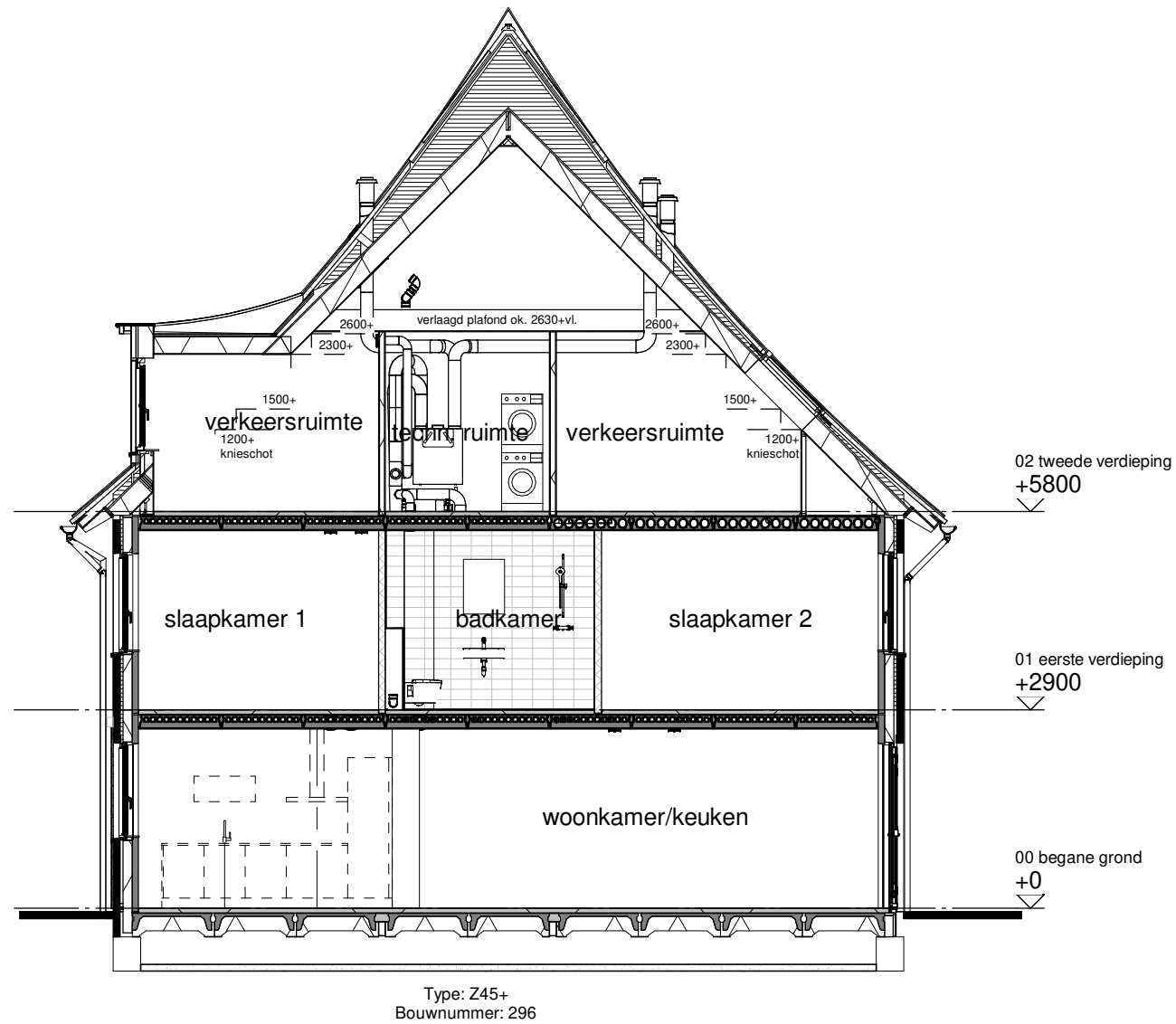

Doorsnede A

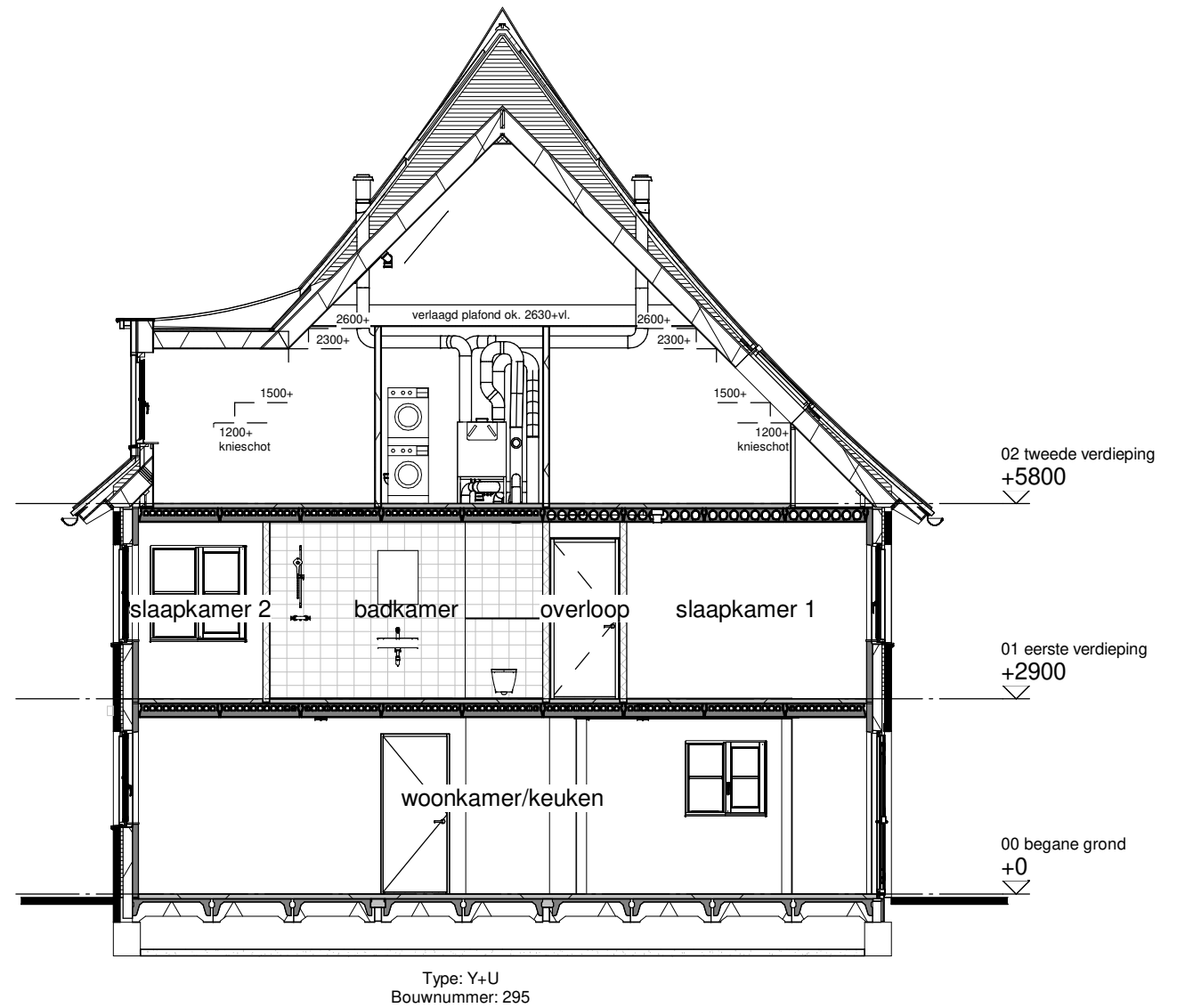

Doorsnede B

**ALLEMAAL  
YIELEYAAL**

Tekening: Doorsnedes blok L4

Woningtype: Z45+, Y+U

Bouwnummer: 295 t/m 301

Bladnummer: VT-L4-00c

Schaal: 1:100

Datum: 30-01-2024

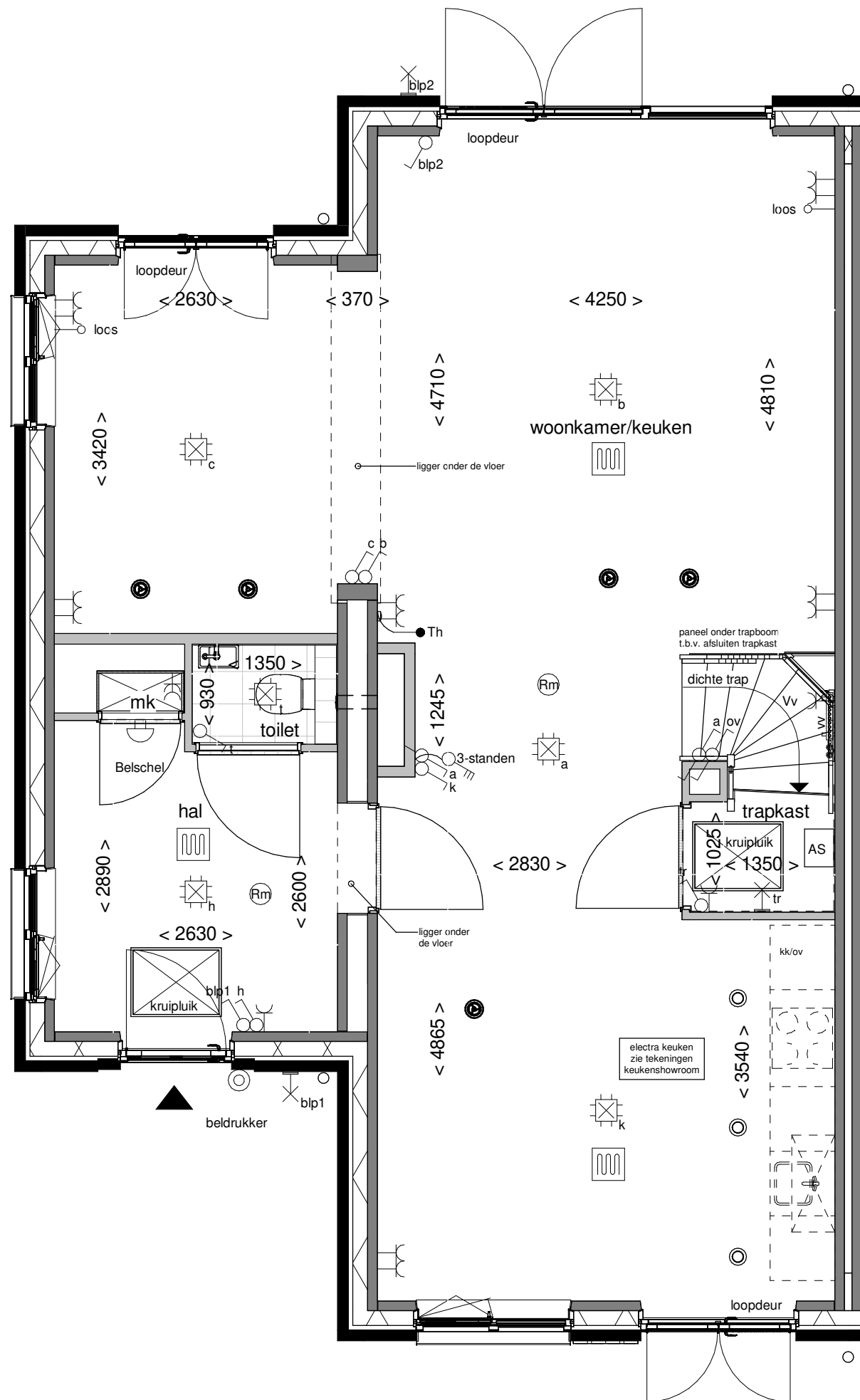

**ALLEMAAL  
VIELEJAAL**

Tekening: Begane grond  
 Woningtype: Y+U  
 Bouwnummer: 295  
 Bladnummer: VT-L4-295a  
 Schaal: 1:50  
 Datum: 30-01-2024

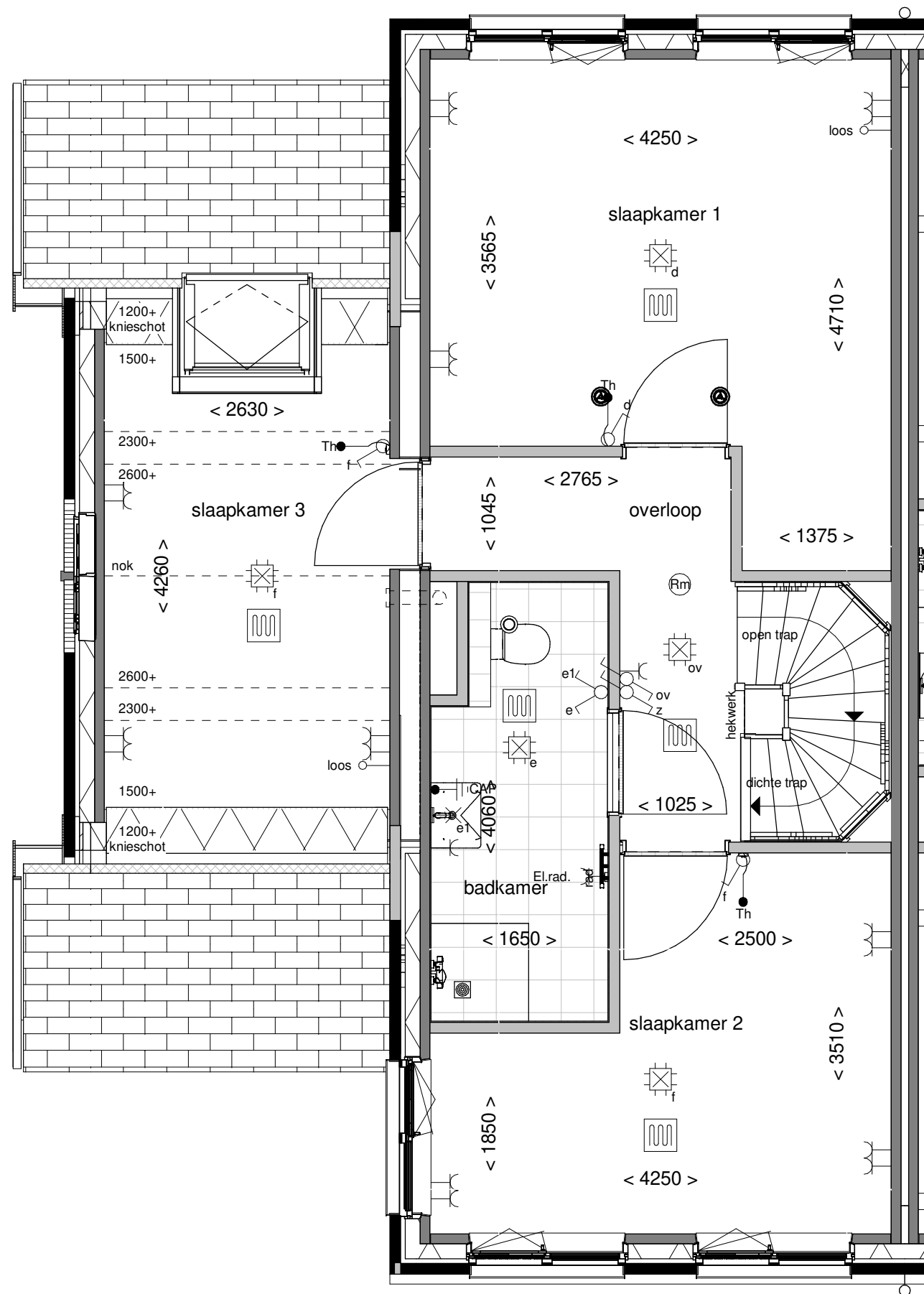

**ALLEMAAL  
YIELEYAAL**

Tekening: Eerste verdieping

Woningtype: Y+U

Bouwnummer: 295

Bladnummer: VT-L4-295b

Schaal: 1:50

Datum: 30-01-2024

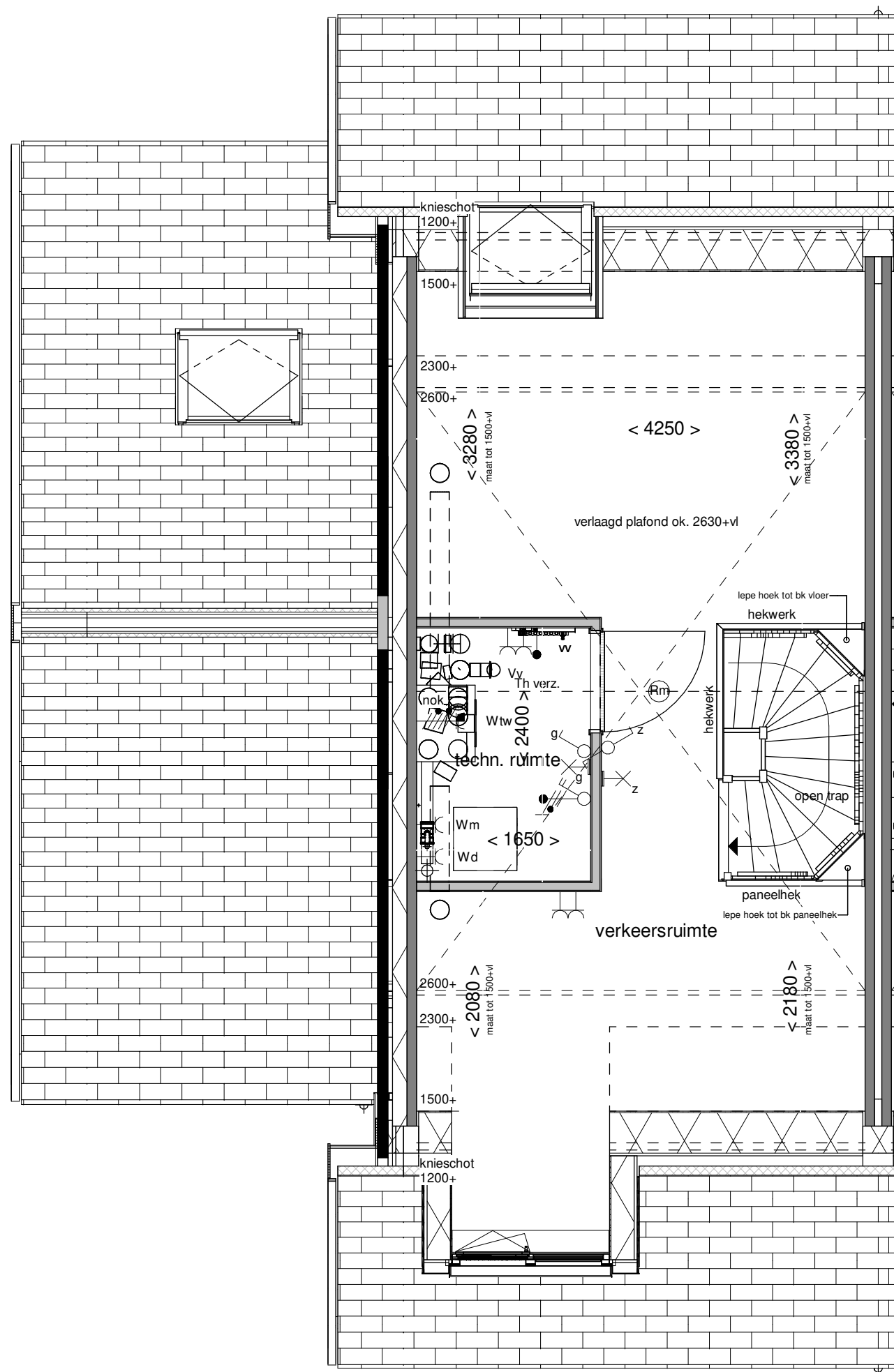

**ALLEMAAL  
YIELEYAAL**

Tekening: Tweede verdieping

Woningtype: Y+U

Bouwnummer: 295

Bladnummer: VT-L4-295c

Schaal: 1:50

Datum: 30-01-2024

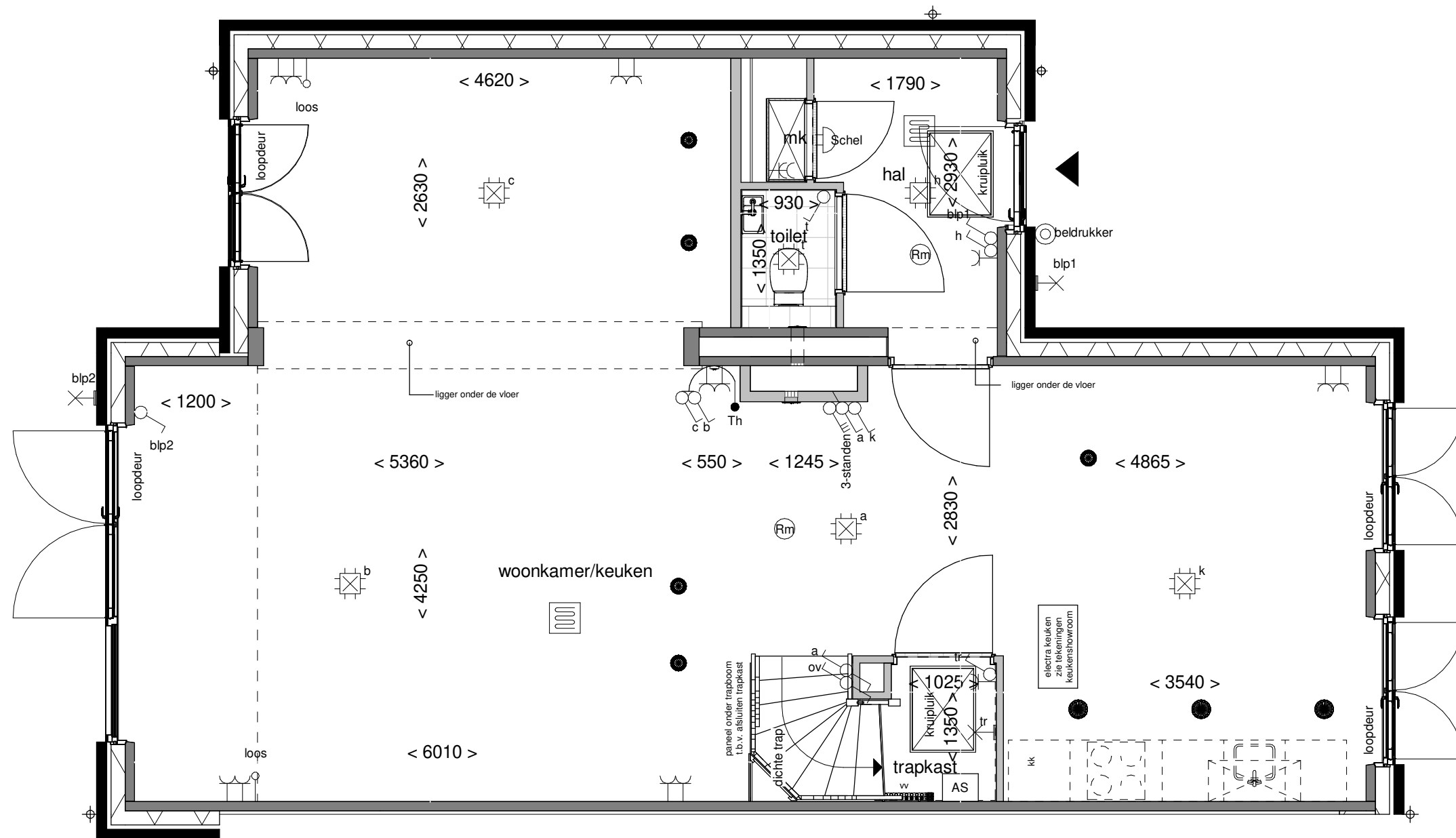

Achtergevel schaal 1:100

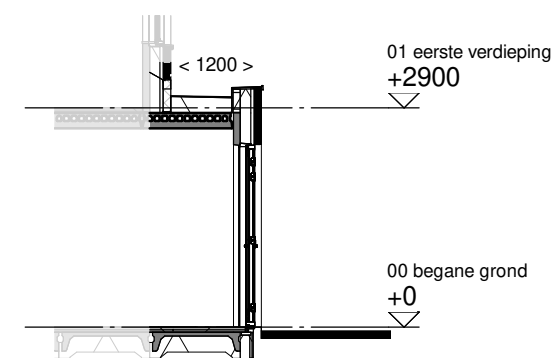

Doorsnede schaal 1:100

**ALLEMAAL  
YIELEYAAL**

Optie: **Uitbouw achtergevel  
1200mm**

Woningtype: **Y45+U**

Bouwnummer: **244,249,295,301**

Optienummer: **0.A.Y.14**

Schaal: **1:50 / 1:100**

Datum: **30-01-2024**





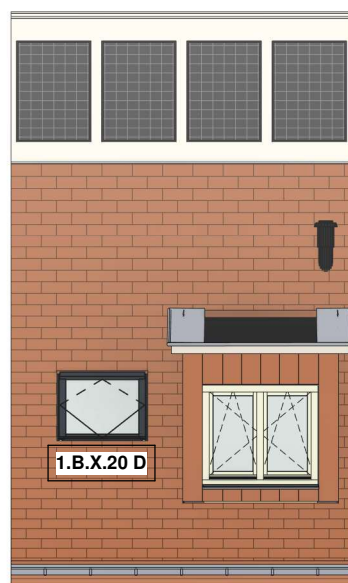
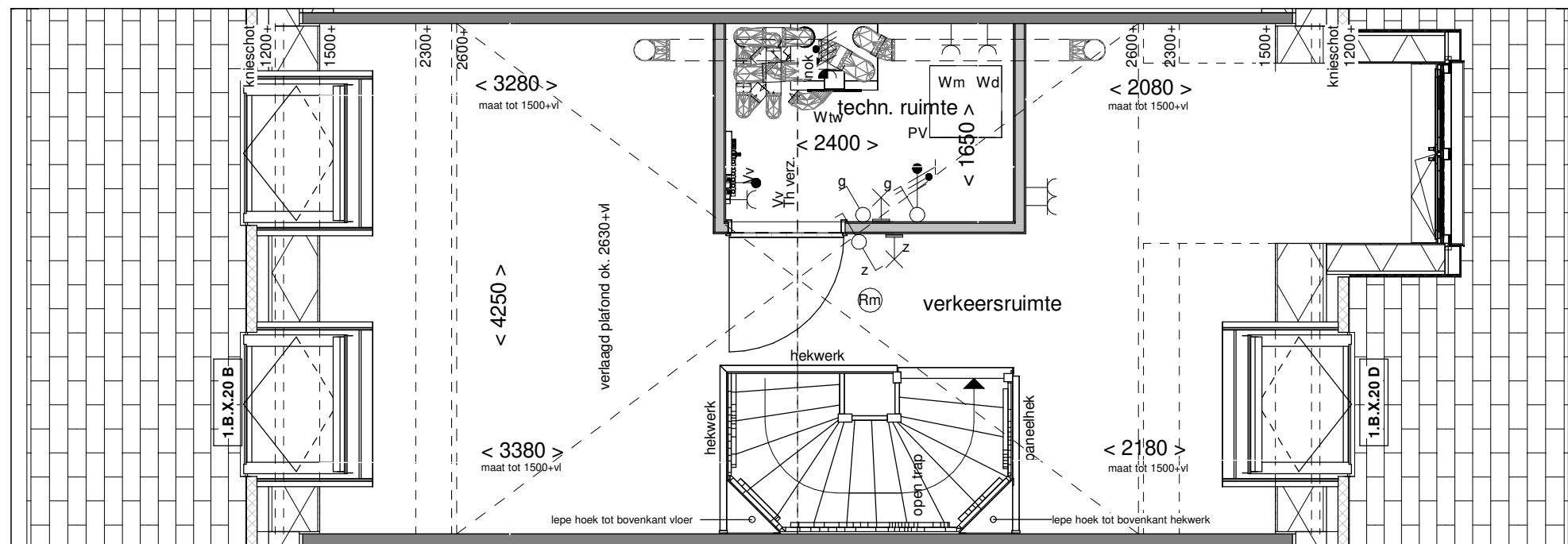

Voorgevel schaal 1:100

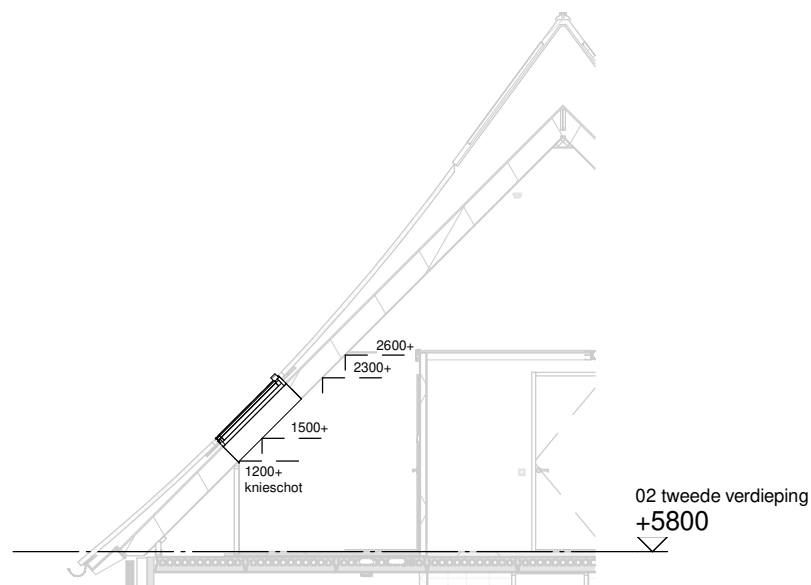

Doorsnede schaal 1:100

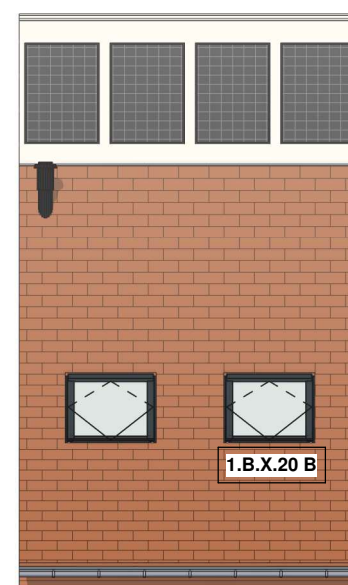

Achtergevel schaal 1:100

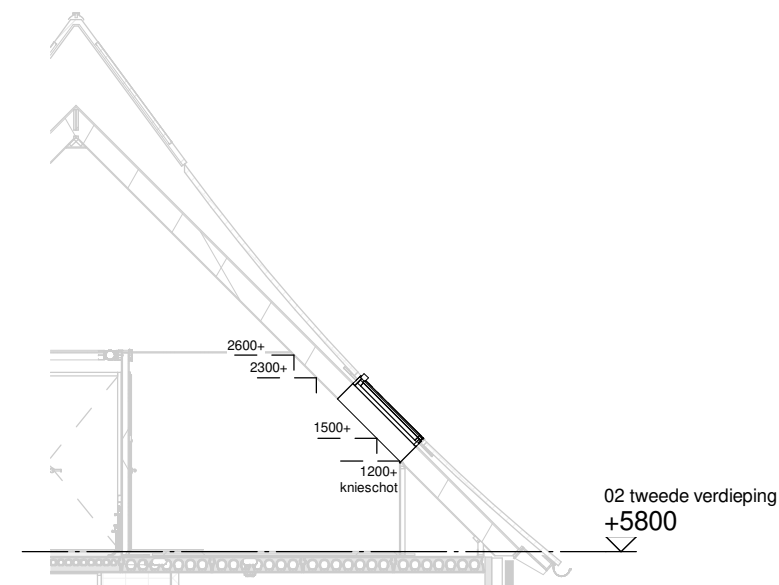

Doorsnede schaal 1:100

**ALLEMAAL  
YIELEYAAL**

Optie: Dakramen voor- en achtergevel

Woningtype: Y45+U

Bouwnummer: 295, 301

Optienummer: 1.B.X.20

Schaal: 1:50/1:100

Datum: 30-01-2024

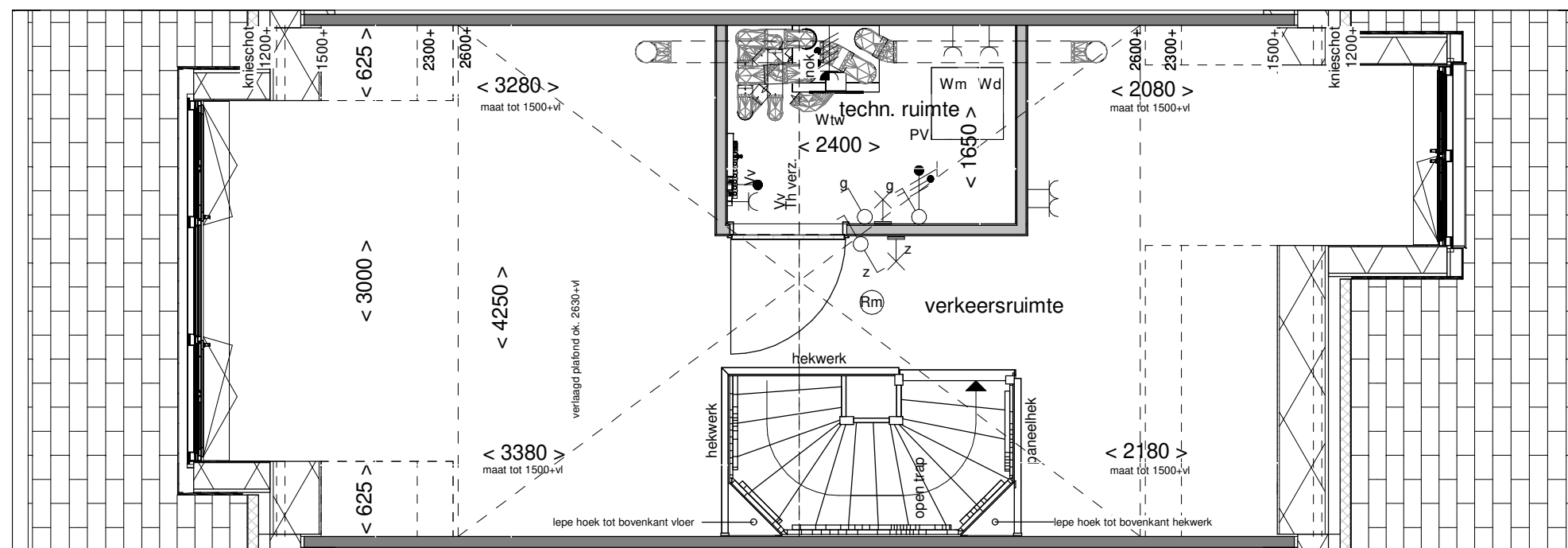

Achtergevel schaal 1:100

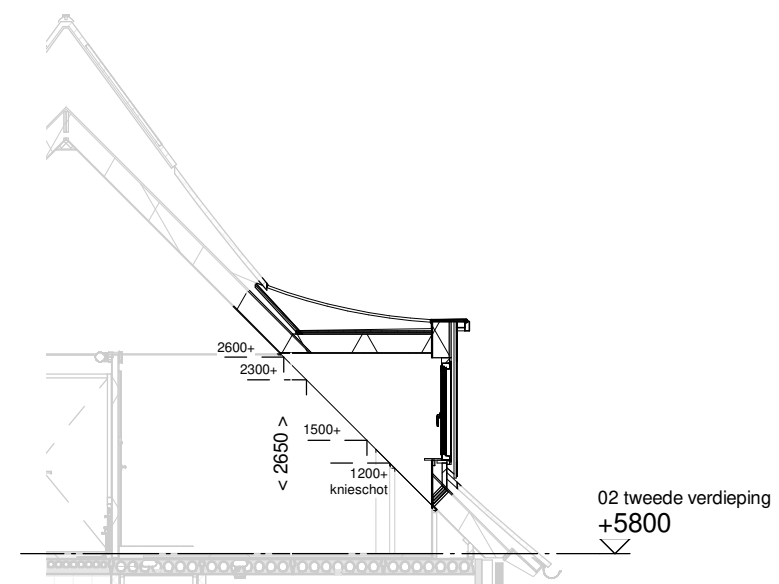

Doorsnede schaal 1:100

**ALLEMAAL  
YIELEYAAL**

Optie: Dakkapel  
achtergevel 3000mm

Woningtype: Y45+U

Bouwnummer: 295, 301

Optienummer: 1.B.X.34

Schaal: 1:50/1:100

Datum: 30-01-2024

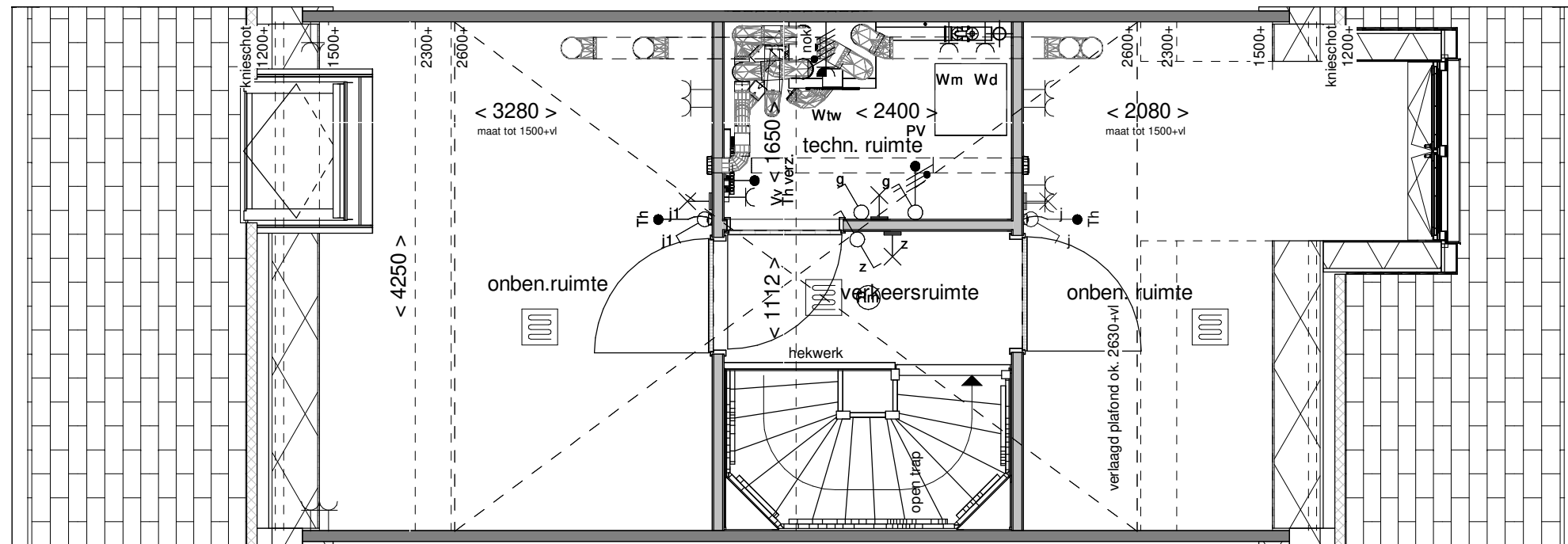

**ALLEMAAL  
YIELEYAAL**

Optie: Indeling techn.- en 2  
onb. ruimtes

Woningtype: Y45+U

Bouwnummer: 295, 301

Optienummer: 1.C.Y.78

Schaal: 1:50

Datum: 30-01-2024

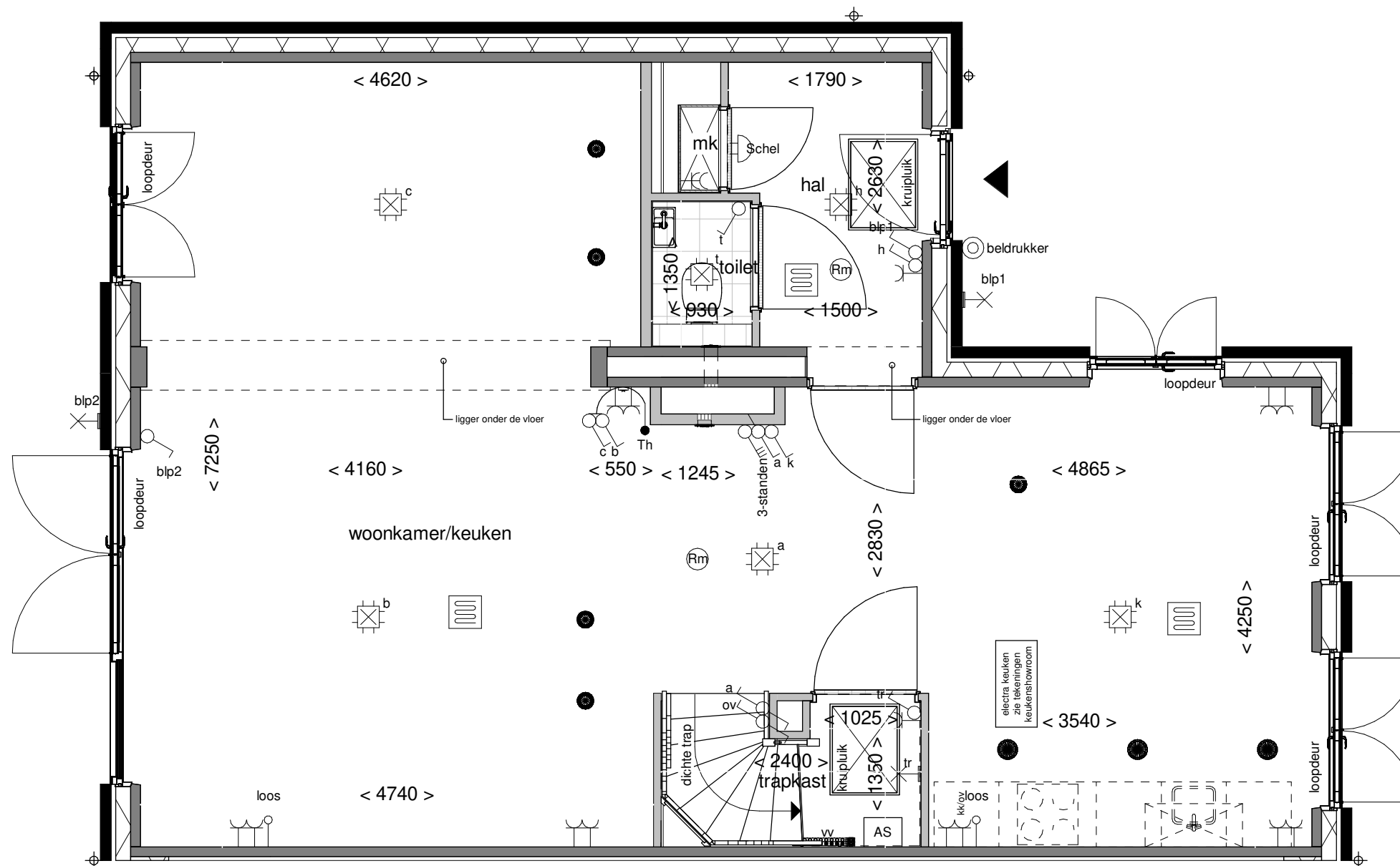

**ALLEMAAL  
YIELEYAAL**

Optie: Wand naast trap

Woningtype: Y45+U

Bouwnummer: -

Optienummer: 1.C.X.10

Schaal: 1:50

Datum: 30-01-2024

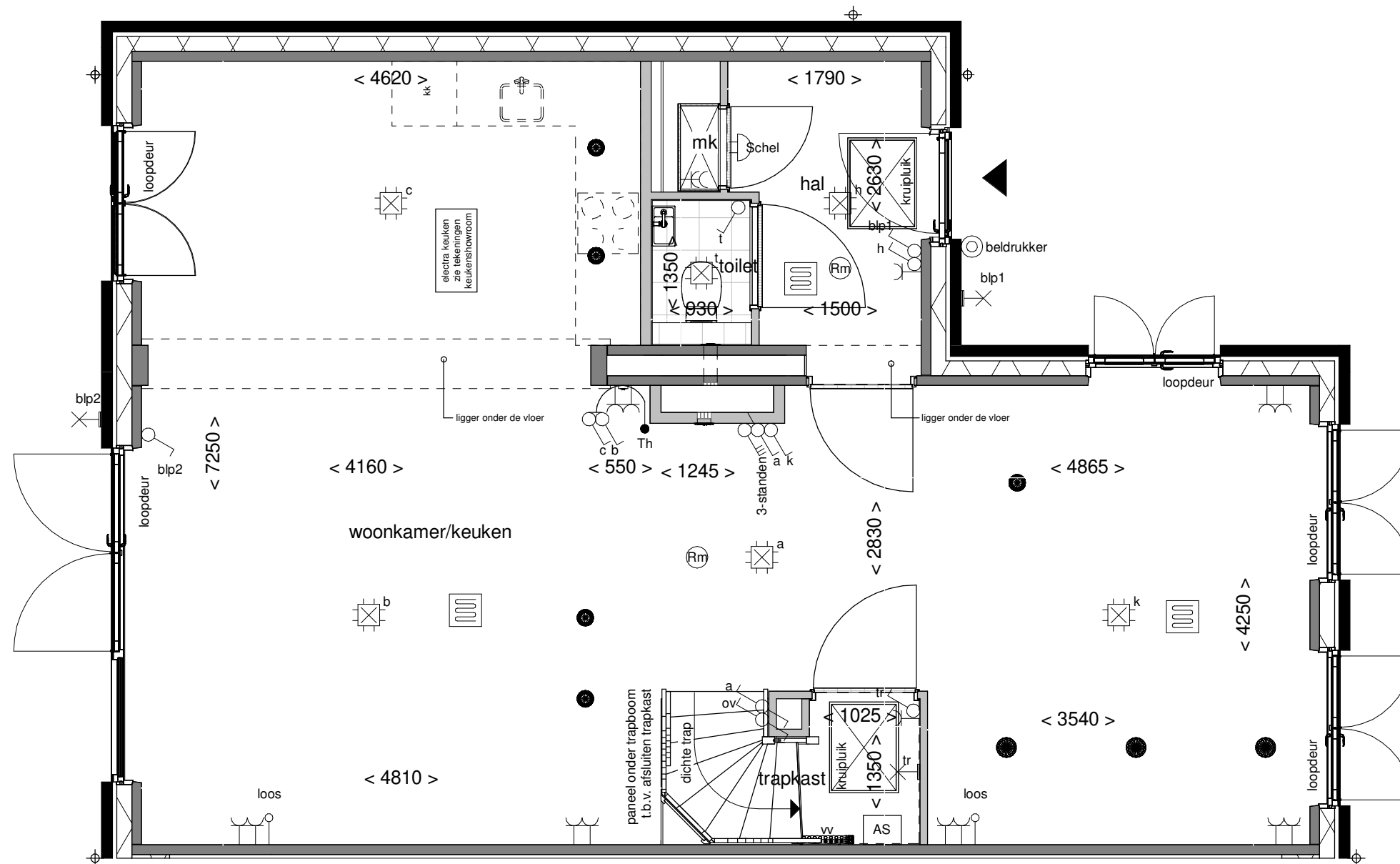

**ALLEMAAL  
YIELEYAAL**

Optie: Keuken in zij-uitbouw

Woningtype: Y45+U

Bouwnummer: 244,249,295,301

Optienummer: 1.C.Y.12

Schaal: 1:50

Datum: 30-01-2024

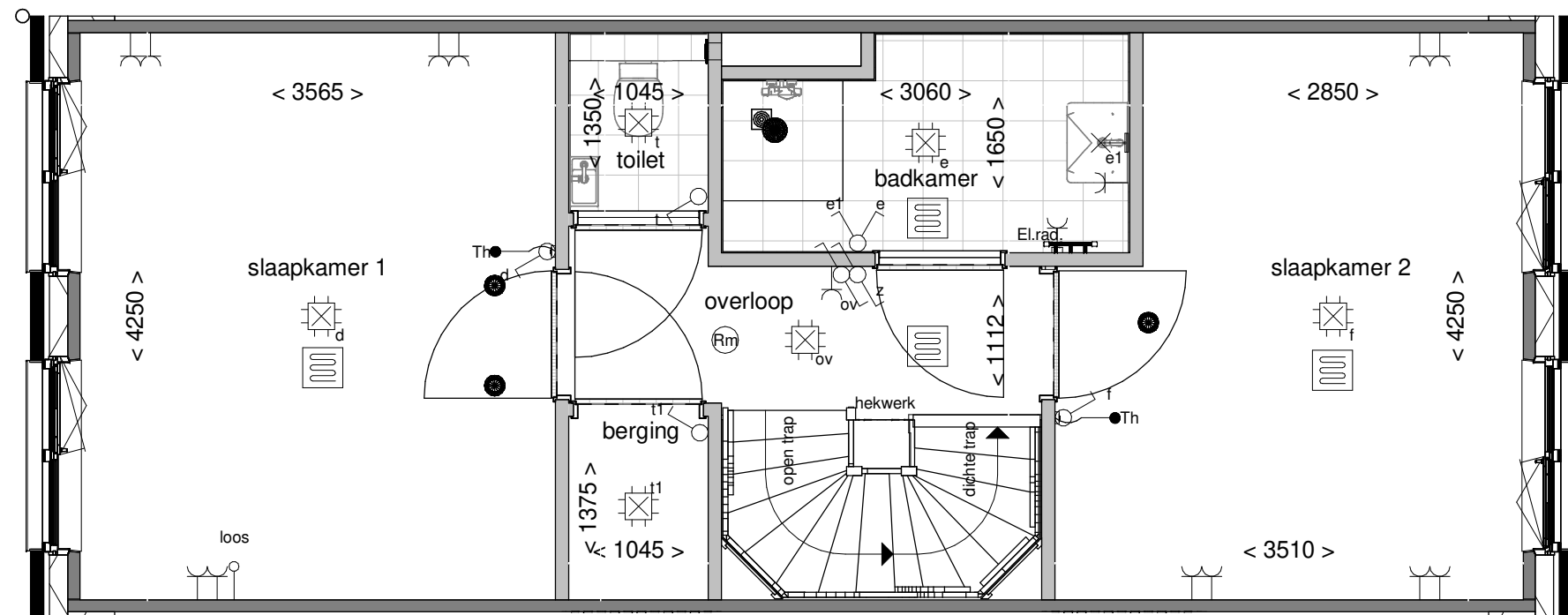

**ALLEMAAL  
YIELEYAAL**

Optie: Kast op overloop

Woningtype: Y45+U

Bouwnummer: 244,249,295,301

Optienummer: 1.C.Y.34

Schaal: 1:50

Datum: 30-01-2024

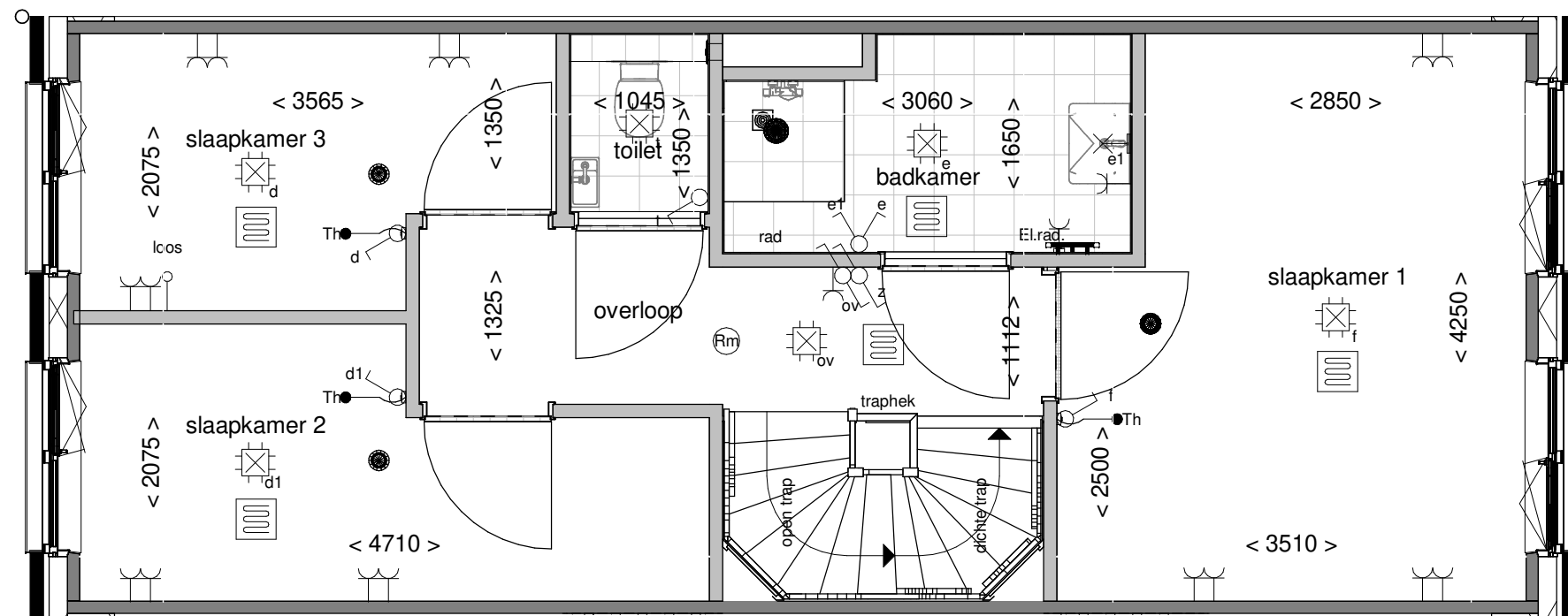

**ALLEMAAL  
VIELEYAAL**

Optie: Twee slaapkamers  
achterzijde

Woningtype: Y45+U

Bouwnummer: 244,249,295,301

Optienummer: 1.C.Y.36

Schaal: 1:50

Datum: 30-01-2024

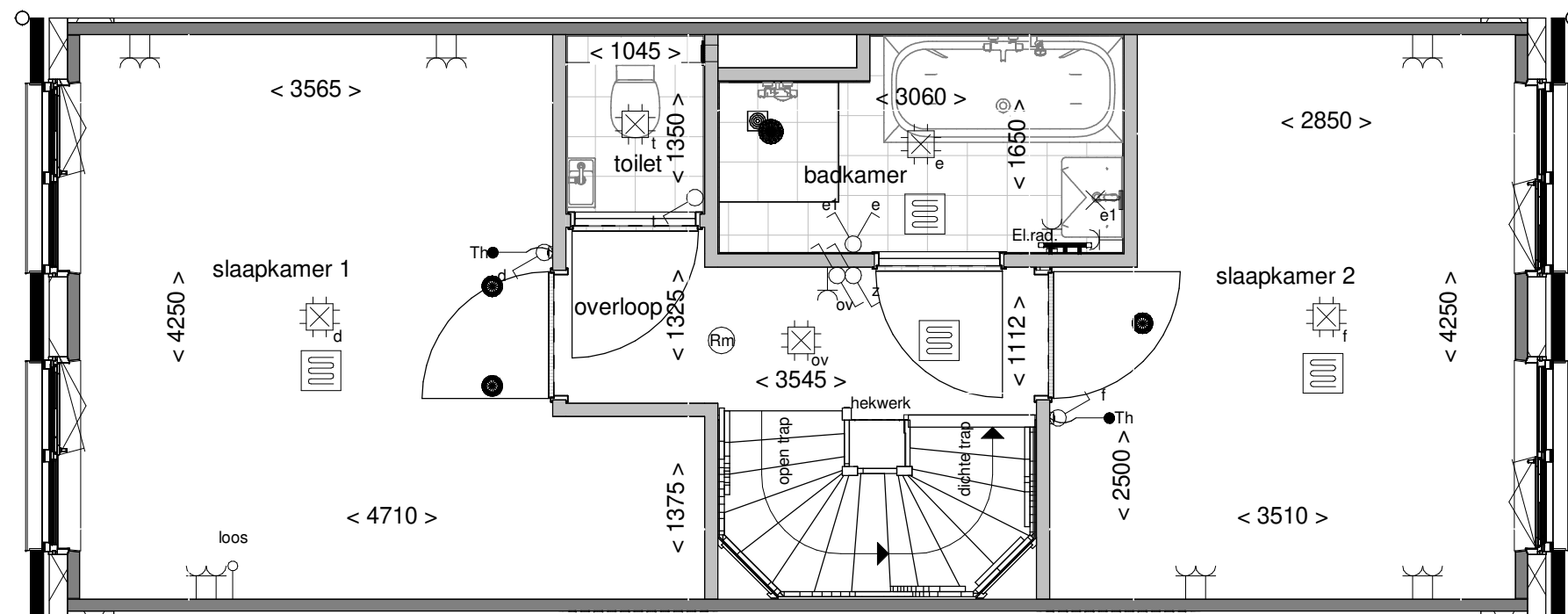

**ALLEMAAL  
YIELEYAAL**

Optie: Bad in badkamer

Woningtype: Y45+U

Bouwnummer: 244,249,295,301

Optienummer: 1.C.Y.40

Schaal: 1:50

Datum: 30-01-2024