

**ALLEMAAL  
YIELEYAAL**

Tekening: Situatie Fase 5-6  
 Woningtype: \_\_\_\_\_  
 Bouwnummer: \_\_\_\_\_  
 Bladnummer: VT-S-01  
 Schaal: 1:1000  
 Datum: 30-01-2024

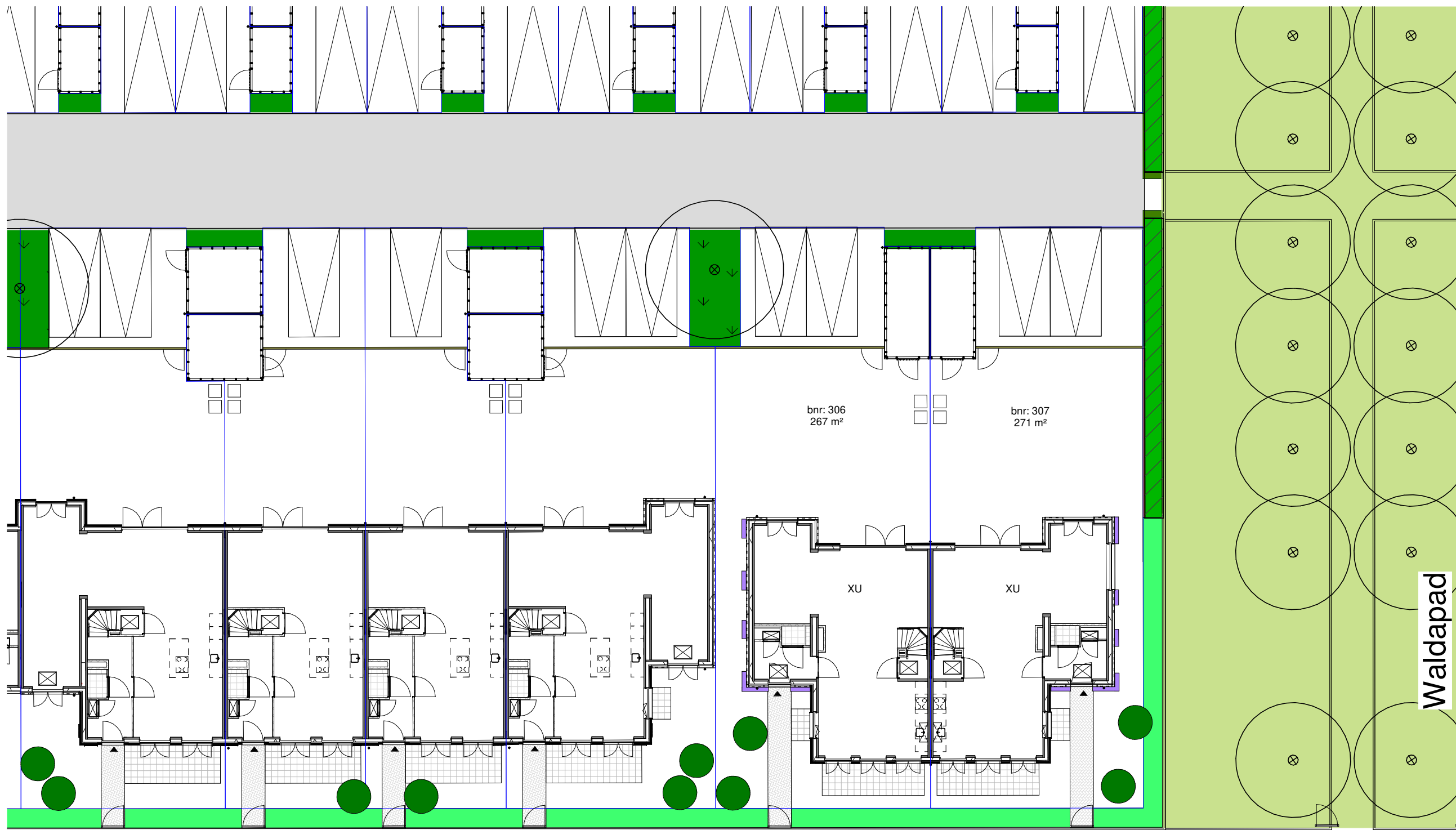

### Renvooi

-  - entree woning
-  - parkeervak eigen terrein
-  - erfgrens
-  - struik type n.t.b. koper
-  - opstelplaats klike
-  - tuinhekje
-  - klinkerbestrating
-  - betontegels 300x300mm
-  - groen strook
-  - haag h=900mm
-  - haag h=1800mm
-  - bamboehok h=1800mm
-  - gaashek met klimplanten en poort h=1600mm
-  - klimplant

parkeerplekken en posities bomen en struiken zijn indicatief







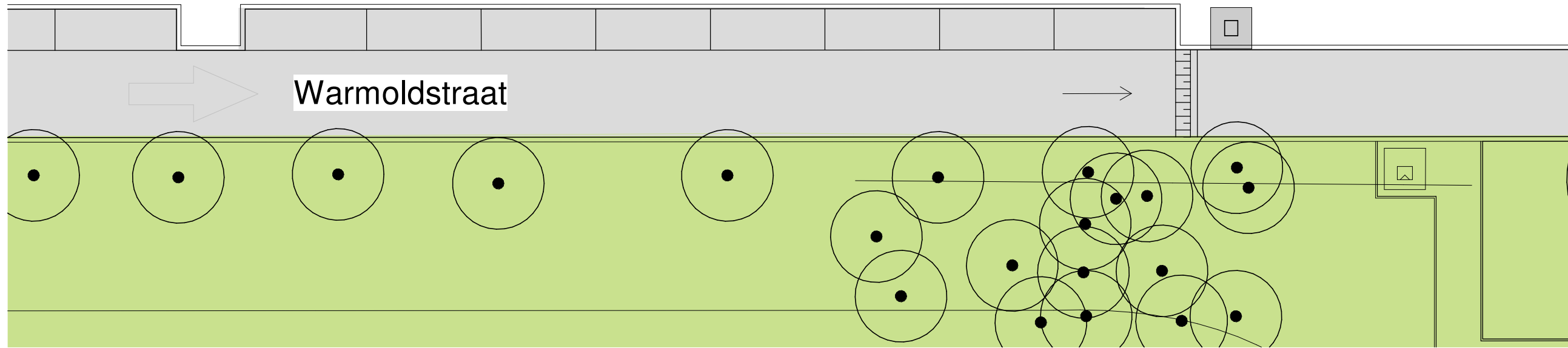





Waldapad

**ALLEMAAL  
YIELEYAAL**

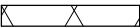

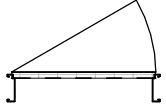
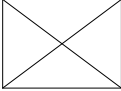



























Tekening: Situatie Blok L6  
 Woningtype: XU  
 Bouwnummer: 306-307  
 Bladnummer: VT-S-04  
 Schaal: 1:200  
 Datum: 30-01-2024

## Renvooi bouwkundig

	metselwerk kleur A
	dakpannen kleur oranje
	entree woning
	metselwerk
	isolatie
	dragende wand
	niet dragende binnenwand
	binnendeurkozijn (met bovenlicht)
	kruipluik
	opstelplaats wasmachine
	opstelplaats wasdroger
	kk/ov
	principe opstelling keukenblok

## Renvooi installaties

	aansluitpunt licht
	aansluitpunt licht, wand
	centraaldoos met lichtpunt
	armatuur aan de wand
	rookmelder
	aansluitpunt niet bedraad
	verdeelinrichting / meterkast / groepenkast
	beldrukker
	schel
	schakelaar, 1-polig
	werkschakelaar tbv PV-panelen
	schakelaar, 3-polig
	schakelaar, wissel
	schakelaar, kruis
	schakelaar, serie
	wandcontactdoos 1-voudig met beschermingscontact
	wandcontactdoos 2-voudig met beschermingscontact, verticaal
	wandcontactdoos 2-voudig met beschermingscontact
	thermostaatleiding, bedraad
	mechanische ventilatie-unit incl. warmteterugwinunit
	warmtepomp
	inblaasventiel mechanische ventilatie
	afzuigventiel mechanische ventilatie
	verdeler vloerverwarming
	Afleverzet stadswarmte
	ruimte voorzien van vloerverwarming
	elektrische radiator
	kanalen in het zicht

### Disclaimer

De op deze tekeningen aangegeven maten zijn circa maten in millimeters en tussen de wanden / vloeren gemeten, waarbij geen rekening is gehouden met enige wandafwerking, plinten, aftimmering, ect. In verband met de nauwkeurige uitwerking van details, constructie, maatvoering, materialen e.d. kunnen er kleine afwijkingen ontstaan ten opzichte van de nu vermelde gegevens. Deze geringe afwijkingen geven geen aanleiding tot verrekening. Aan de op deze tekening aangegeven maten kunnen derhalve geen rechten worden ontleend. De op deze tekeningen aangegeven maatvoering is niet geschikt voor opdrachten aan derden door koper(s). De posities van aansluitingen en installatie onderdelen zijn indicatief op tekening aangegeven. De exacte aantallen en posities zullen na berekening in het werk door de installateurs worden bepaald en kunnen afwijken van deze tekening.

**ALLEMAAL  
YIELEYAAL**

Tekening: Renvooi

Woningtype: -

Bouwnummer: -

Bladnummer: VT-0-00c

Schaal: -

Datum: 30-01-2024



Type: XU  
bwnr: 306

Type: XU  
bwnr: 307

Voorgevel



Type: XU  
bwnr: 307

Type: XU  
bwnr: 306

Achtergevel

ALLEMAAL  
YIELEYAAL

Tekening: Gevels blok L6

Woningtype: XU

Bouwnummer: 306/ 307

Bladnummer: VT-L6-00a

Schaal: 1:50

Datum: 30-01-2024



Type: XU  
Bouwnummer: 306

Linker zijgevel



Type: XU  
Bouwnummer: 307

Rechter zijgevel

**ALLEMAAL  
YIELEYAAL**

Tekening: Zijgevels blok L6

Woningtype: XU

Bouwnummer: 306/ 307

Bladnummer: VT-L6-00b

Schaal: 1:50

Datum: 30-01-2024

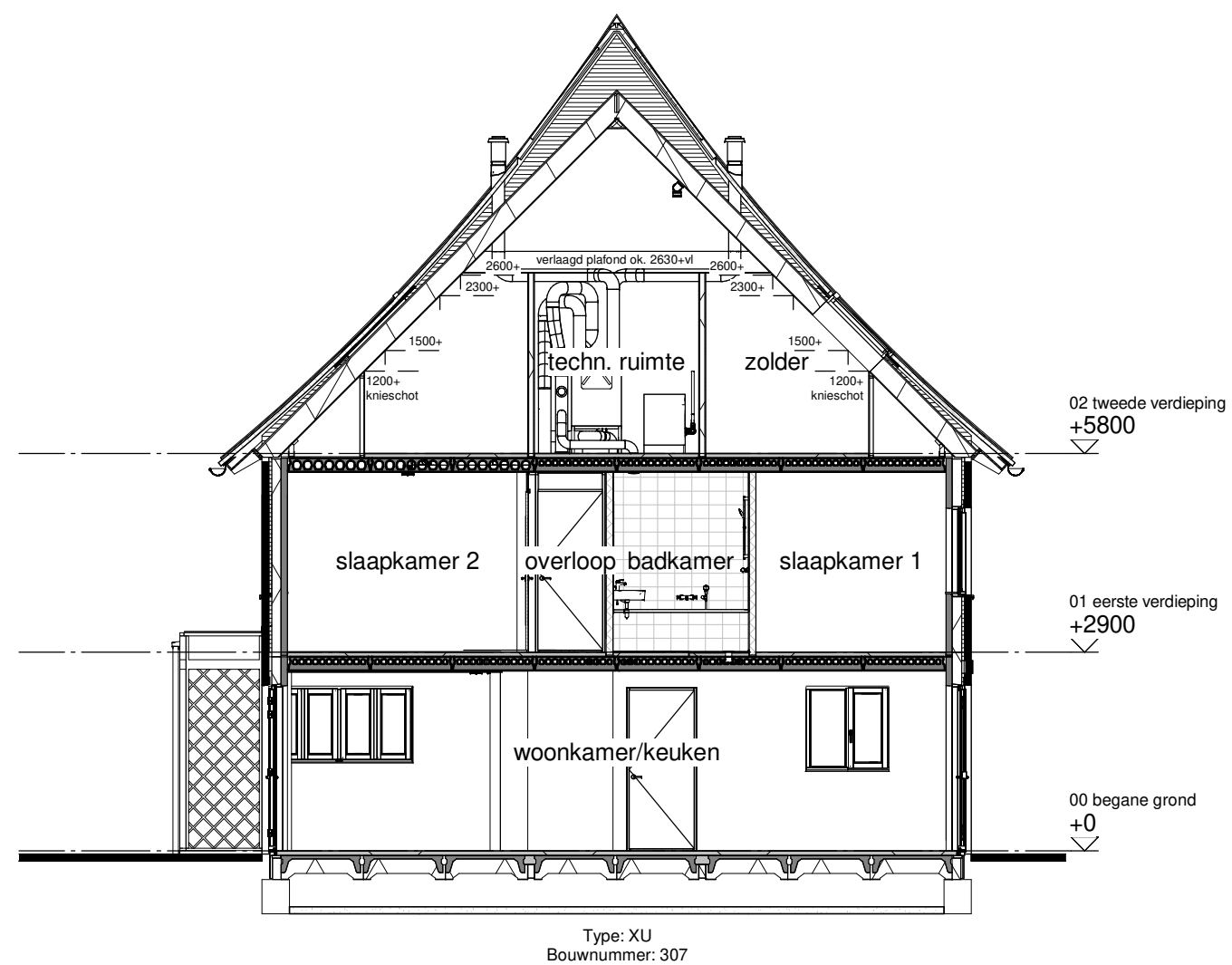

Doorsnede A

ALLEMAAL  
VIELEJAAL

Tekening: Doorsnede blok L6

Woningtype: XU

Bouwnummer: 306/ 307

Bladnummer: VT-L6-00c

Schaal: 1:50

Datum: 30-01-2024

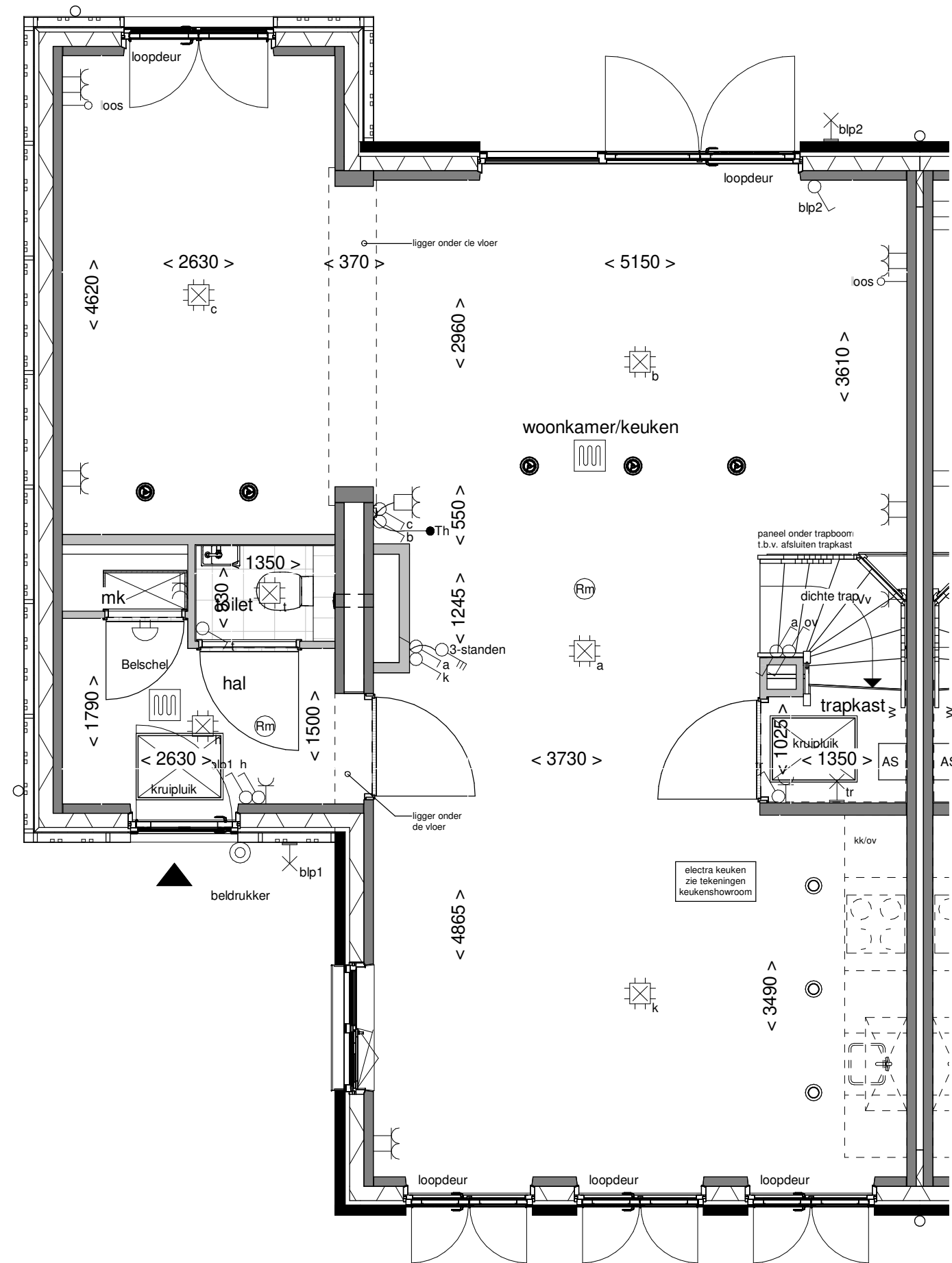

**ALLEMAAL  
YIELEYAAL**

Tekening: Begane grond  
 Woningtype: XU  
 Bouwnummer: 306  
 Bladnummer: VT-L6-306a  
 Schaal: 1:50  
 Datum: 30-01-2024

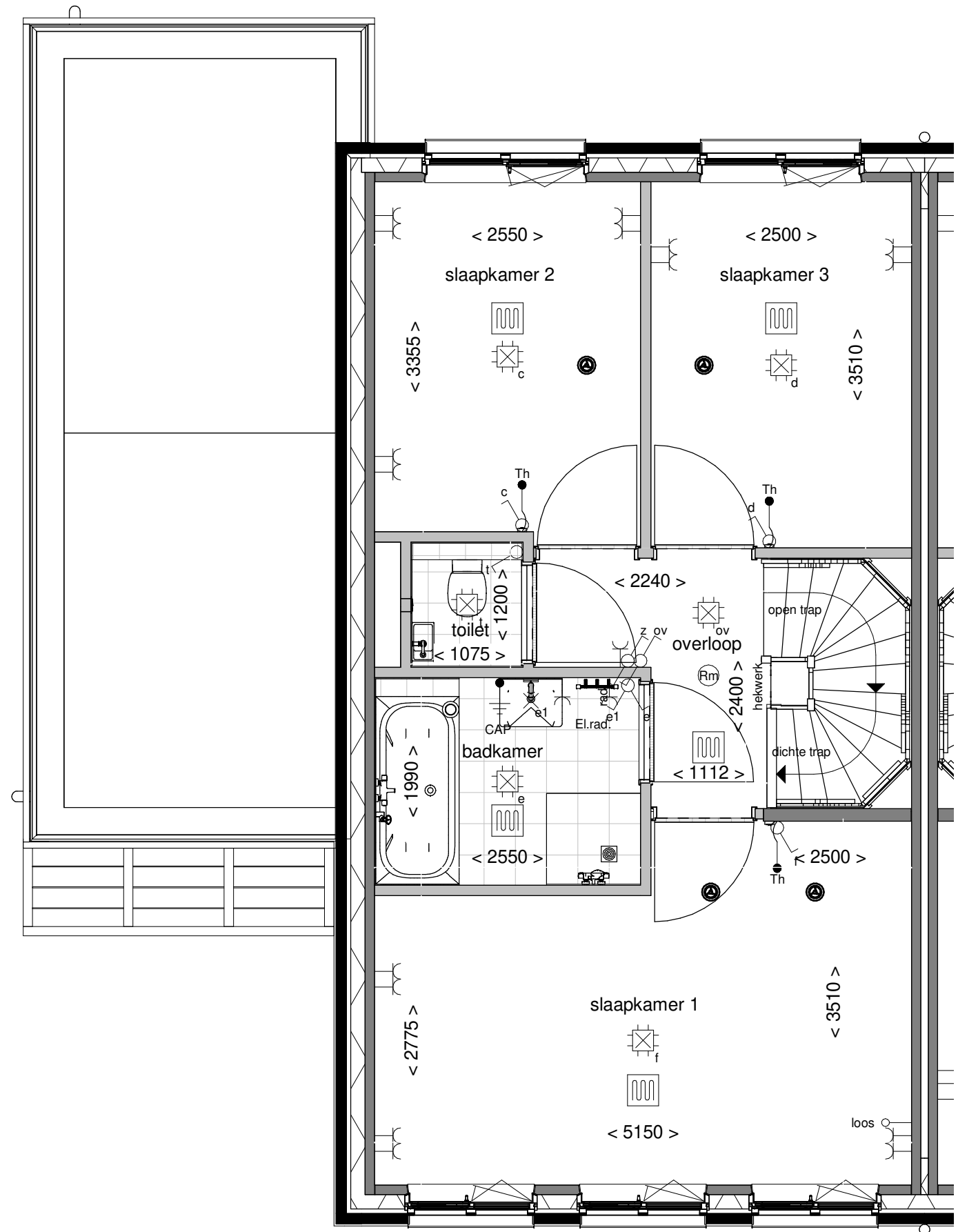

**ALLEMAAL  
YIELEYAAL**

Tekening: Eerste verdieping  
 Woningtype: XU  
 Bouwnummer: 306  
 Bladnummer: VT-L6-306b  
 Schaal: 1:50  
 Datum: 30-01-2024



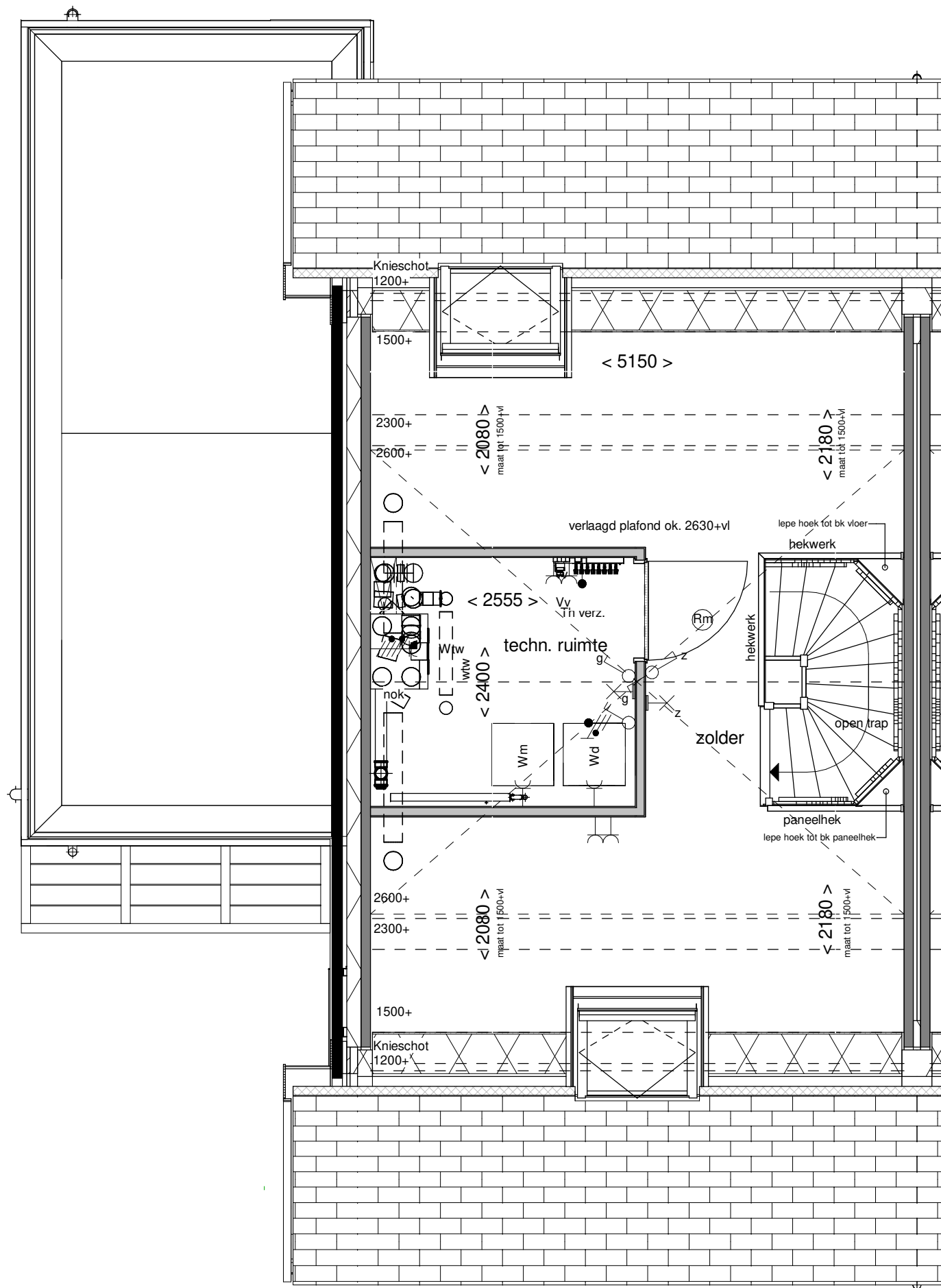

**ALLEMAAL  
VIELEJAAL**

Tekening: Tweede verdieping

Woningtype: XU

Bouwnummer: 306

Bladnummer: VT-L6-306c

Schaal: 1:50

Datum: 30-01-2024

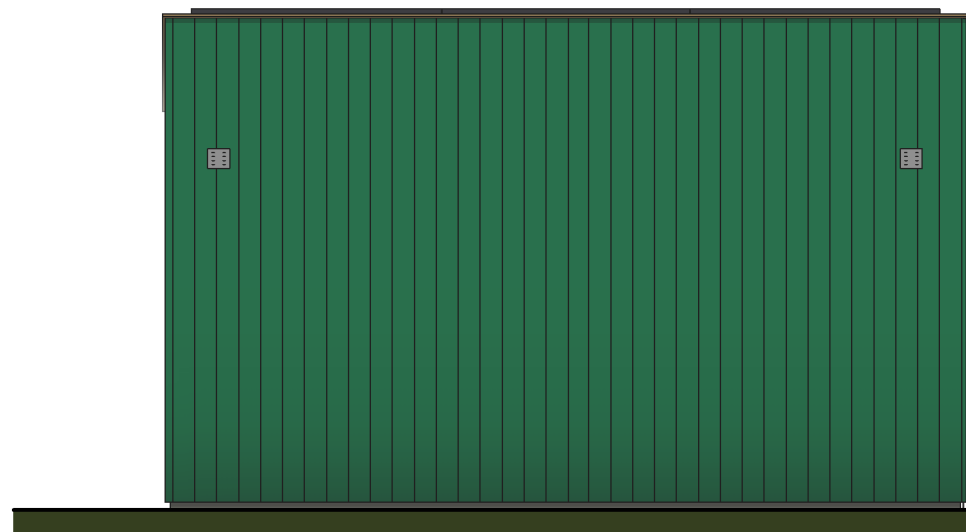

Voorgevel

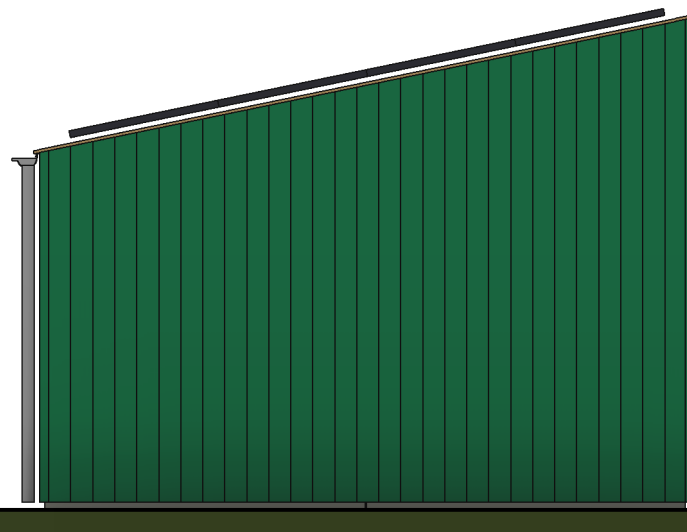

Linker zijgevel



Rechter zijgevel

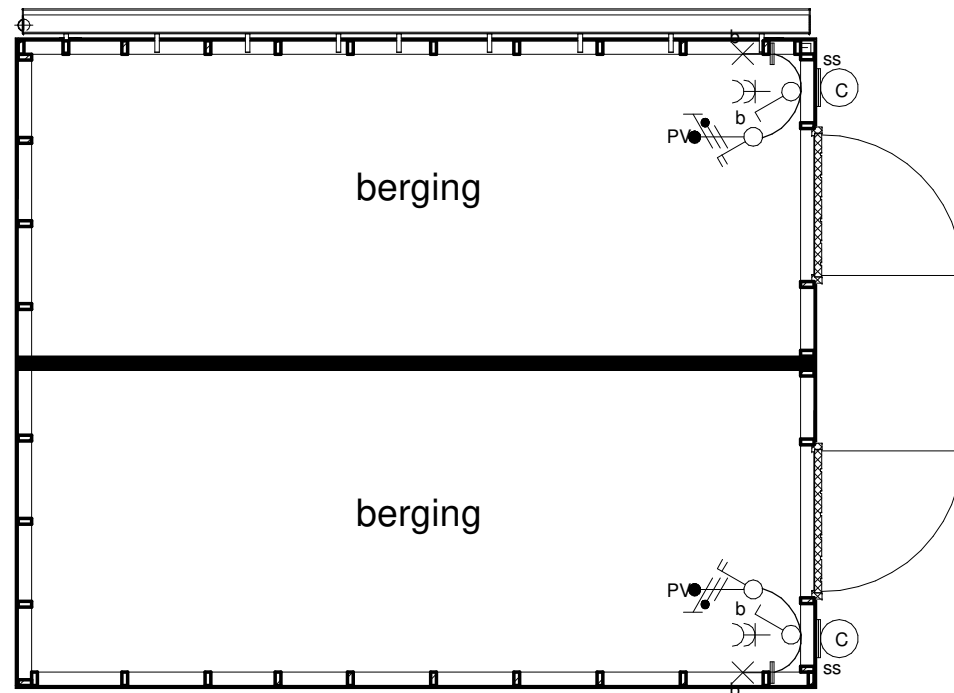

Begane grond

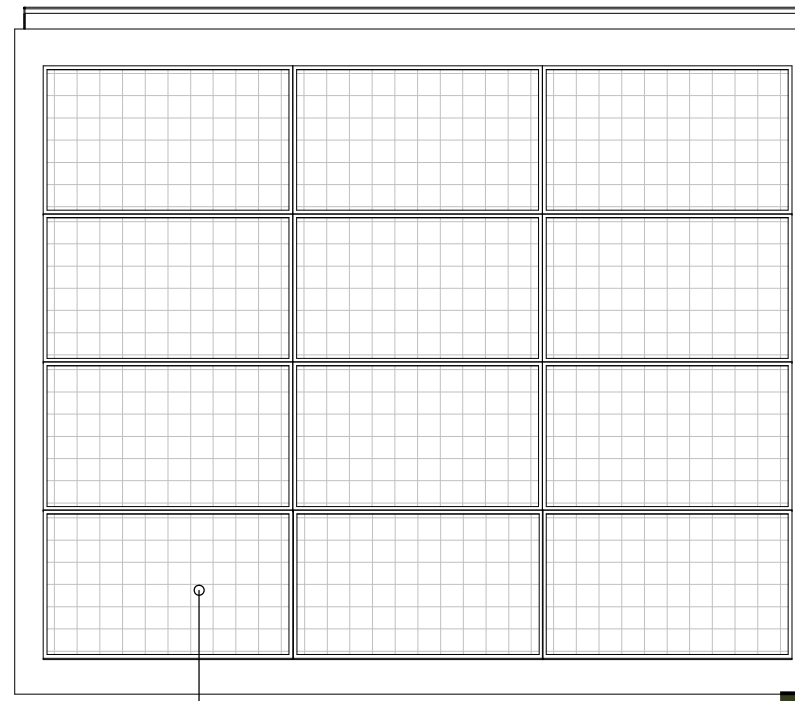

Dakaanzicht

maximaal aantal pv-panelen weergegeven  
aantal kan verschillen per woning/berging

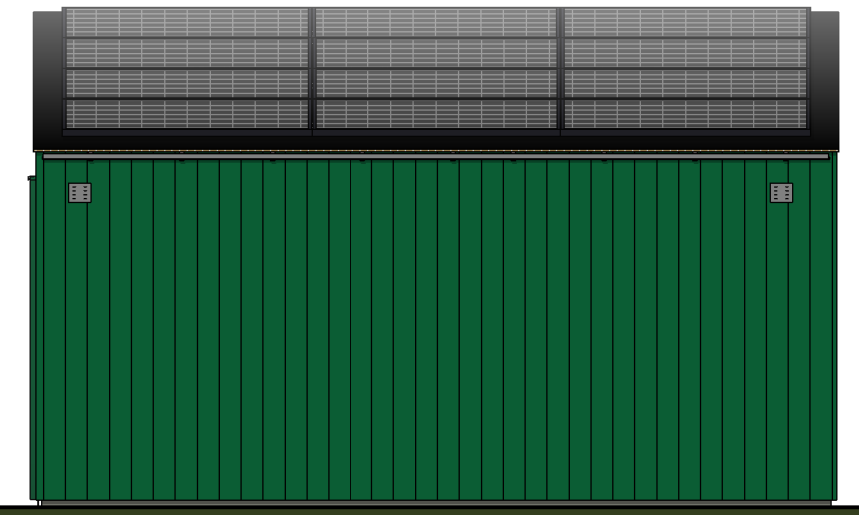

Achtergevel



Doorsnede A-A

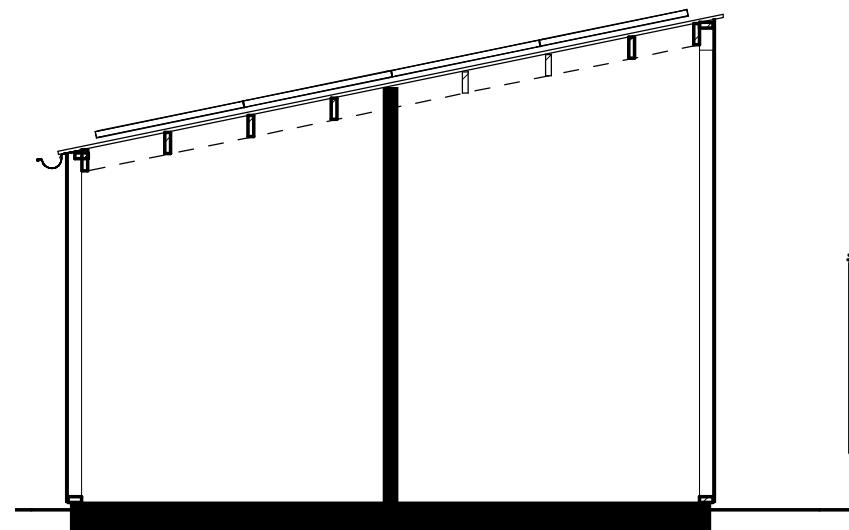

Doorsnede B-B

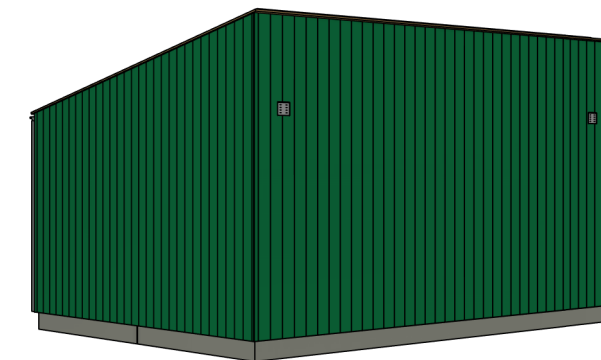

3D aanzicht

**Gespiegeld:**  
bnr. 306 - 307

**ALLEMAAL  
YIELEYAAL**

Tekening: **Berging E**

Woningtype: -

Bouwnummer: **306-307**

Bladnummer: **VT-BE06**

Schaal: **1:50**

Datum: **30-01-2024**

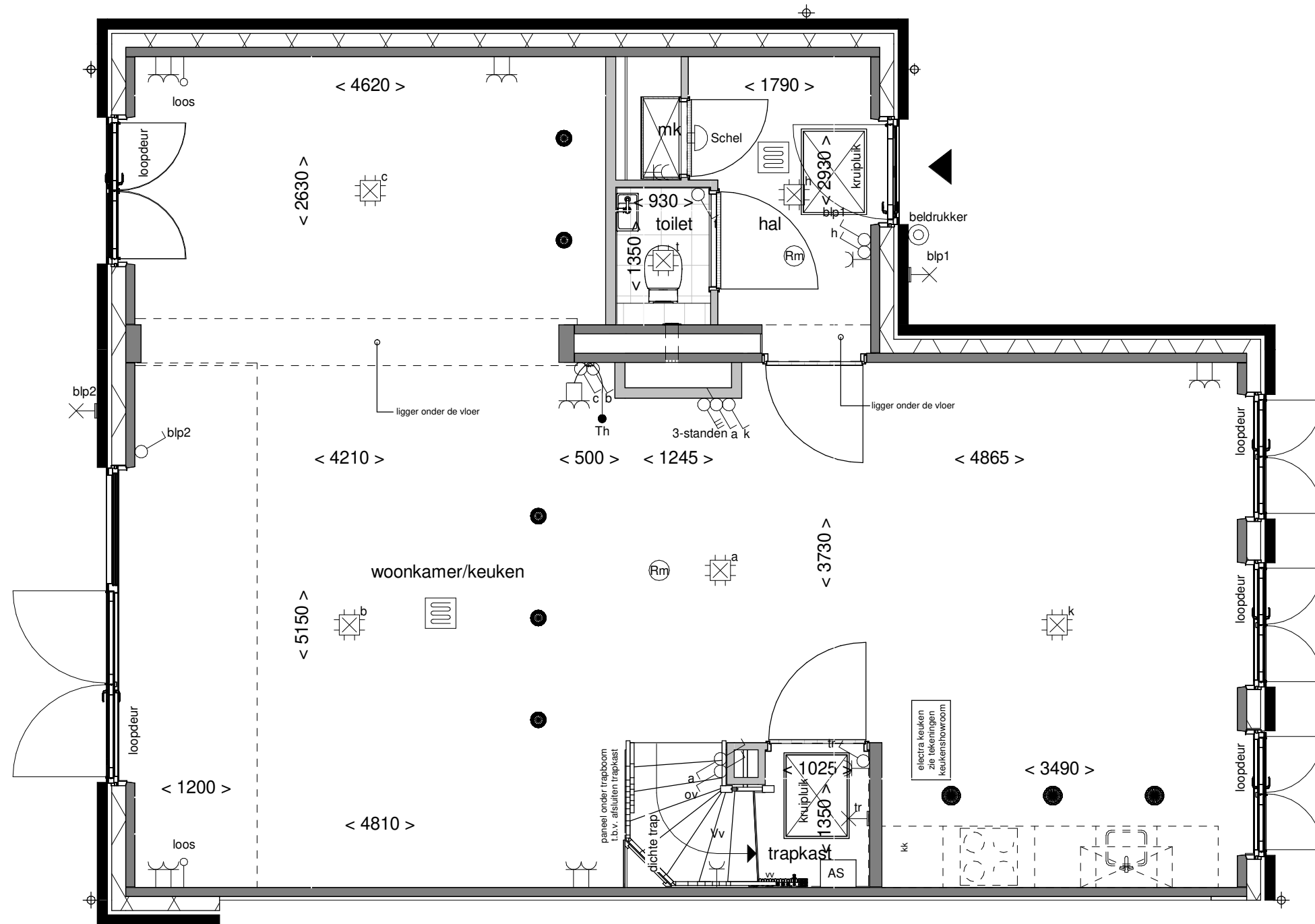

Achtergevel schaal 1:100

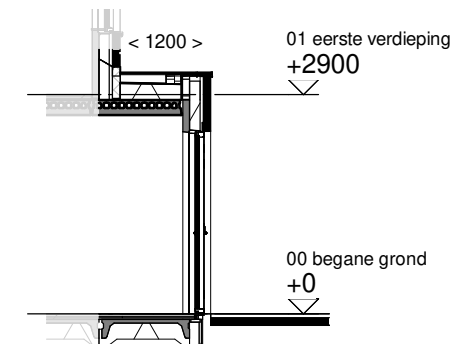

Doorsnede schaal 1:100

**ALLEMAAL  
VIELEYAAL**

Optie: **Uitbouw achtergevel  
1200mm**

Woningtype: **X54U**

Bouwnummer: -

Optienummer: **1.A.X.12**

Schaal: **1:50 / 1:100**

Datum: **30-01-2024**

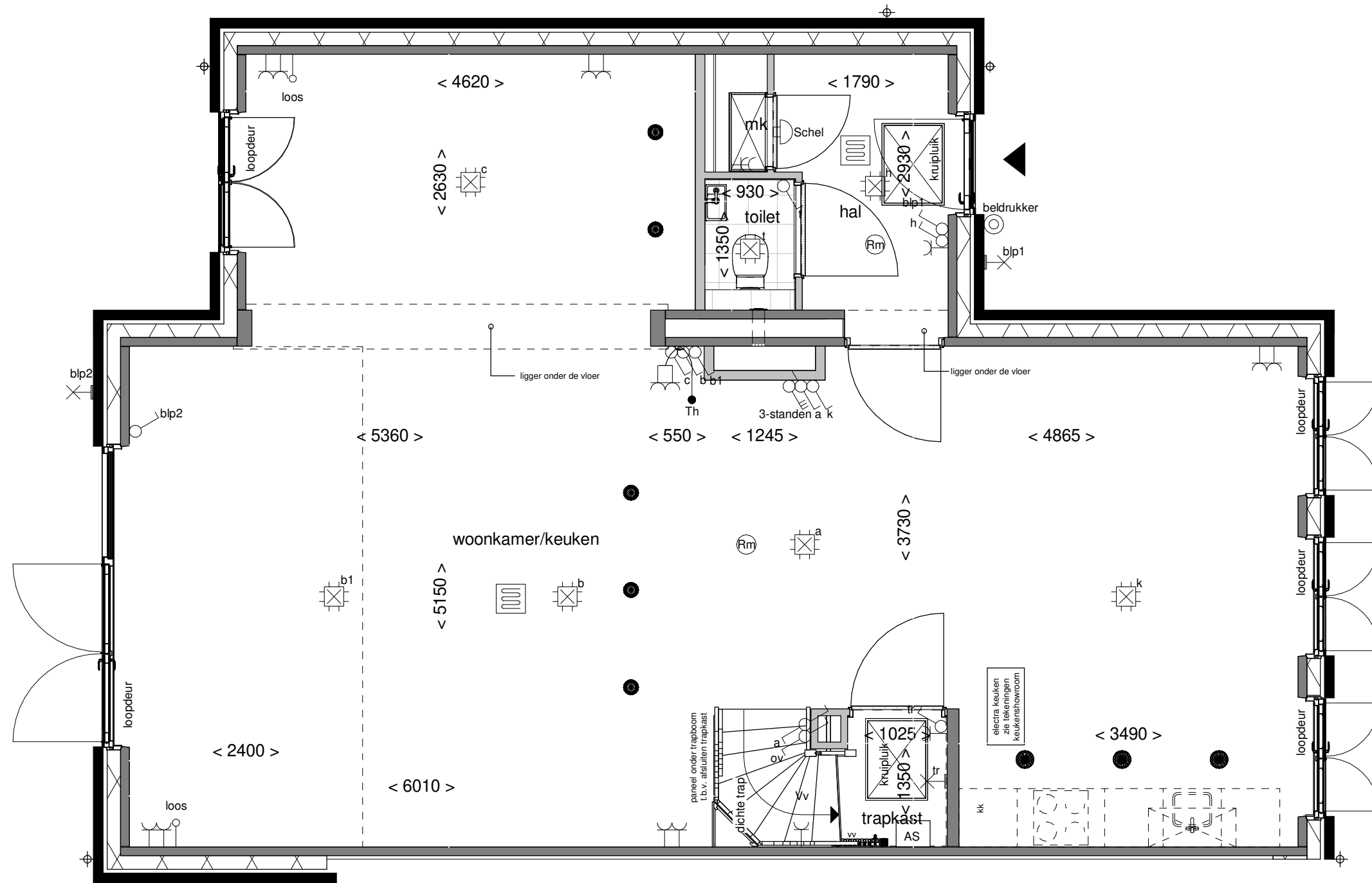

Achtergevel schaal 1:100

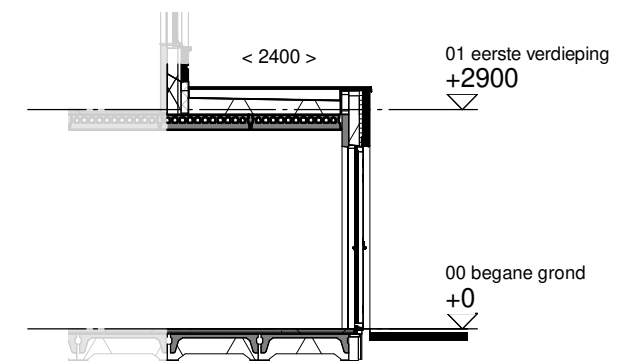

Doorsnede schaal 1:100

**ALLEMAAL  
VIELEYAAL**

Optie: **Uitbouw achtergevel  
2400mm**

Woningtype: **X54U**

Bouwnummer: **-**

Optienummer: **1.A.X.32**

Schaal: **1:50 / 1:100**

Datum: **30-01-2024**

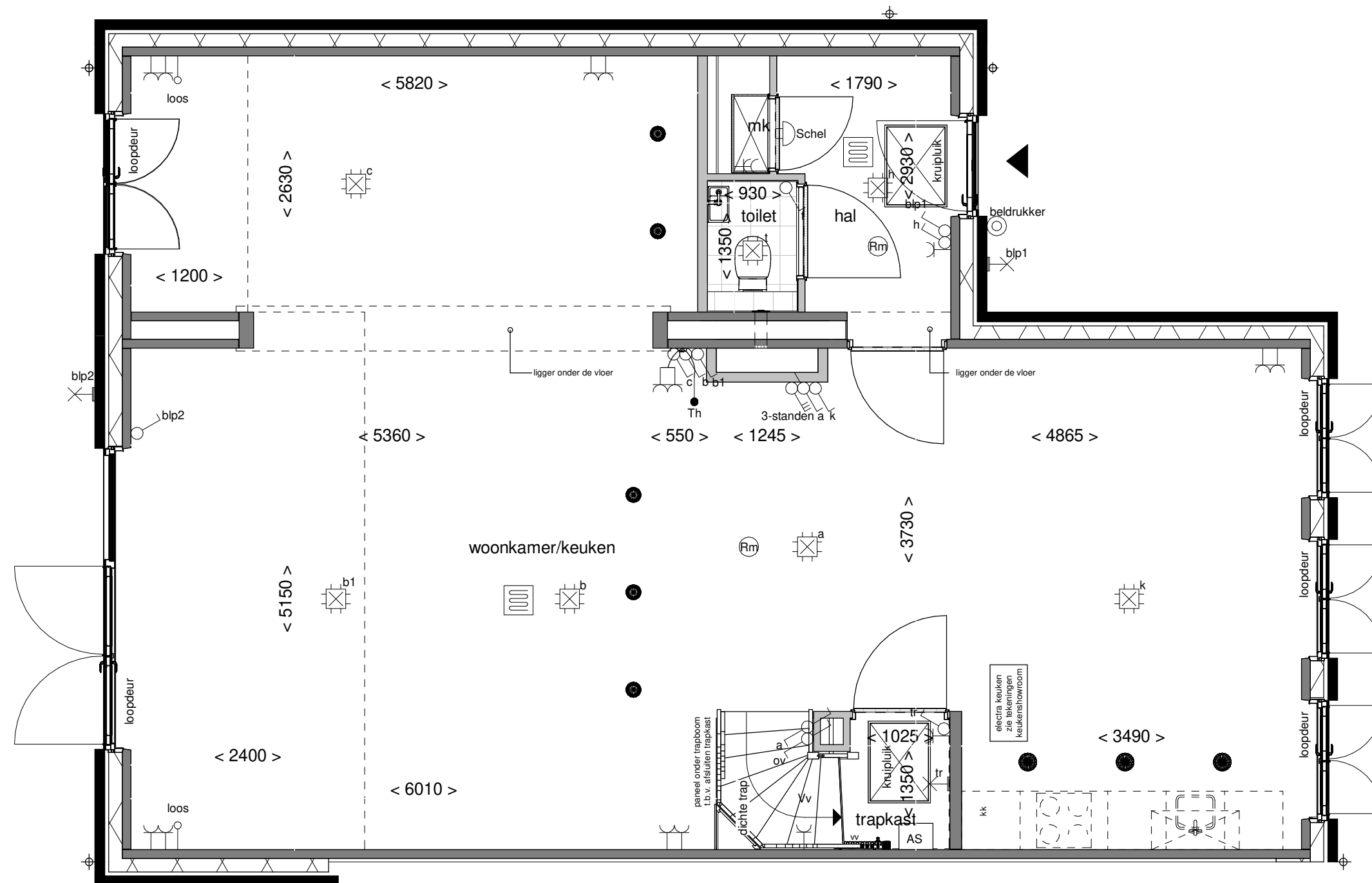

Achtergevel schaal 1:100

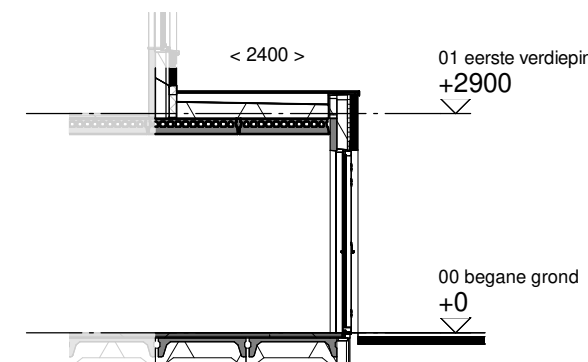

Doorsnede schaal 1:100

**ALLEMAAL  
YIELEYAAL**

Optie: Uitb. achter 2400mm  
+ zijuitbouw 1200mm

Woningtype: X54U

Bouwnummer: -

Optienummer: 1.A.X.52B

Schaal: 1:50 / 1:100

Datum: 30-01-2024

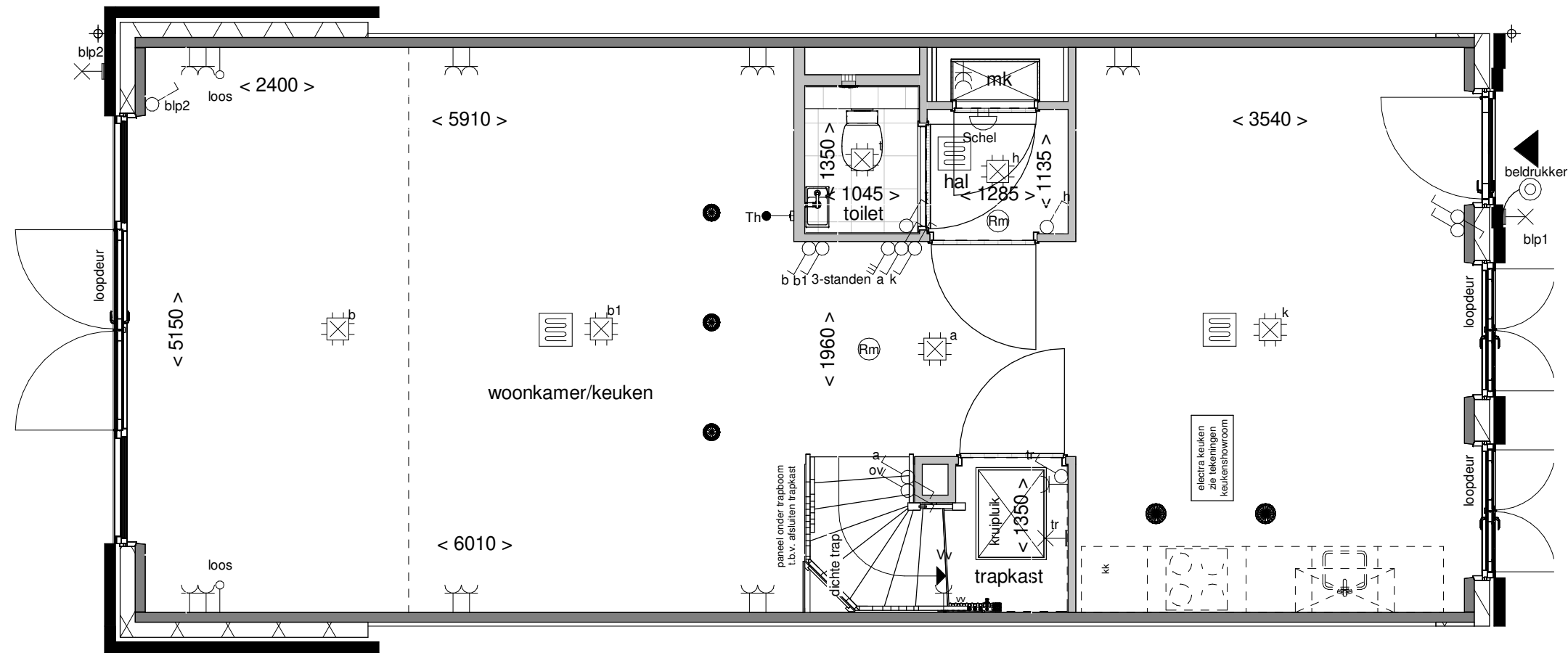

Achtergevel schaal 1:100

**ALLEMAAL  
YIELEYAAL**

- Optie: Dubbele deuren  
achtergevel 3900mm

---

- Woningtype: X54

---

- Bouwnummer: -

---

- Optienummer: 1.A.X.62

---

- Schaal: 1:50 / 1:100

---

- Datum: 30-01-2024

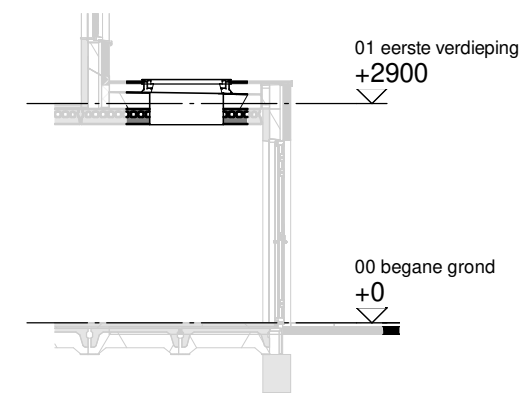
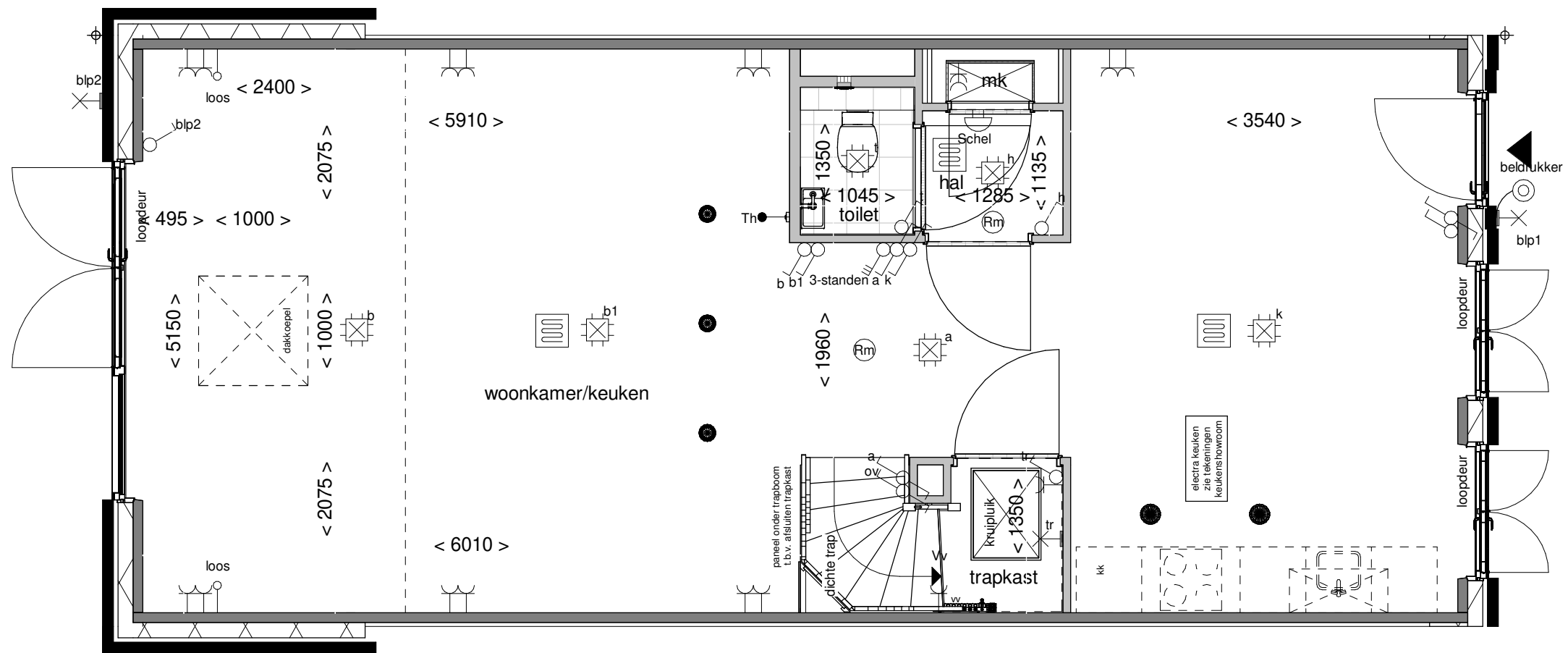

Doorsnede schaal 1:100

**ALLEMAAL  
YIELEYAAL**

Optie: Lichtkoepel in uitbouw 2400mm

Woningtype: X54

Bouwnummer: -

Optienummer: 1.B.X.10

Schaal: 1:50 / 1:100

Datum: 30-01-2024

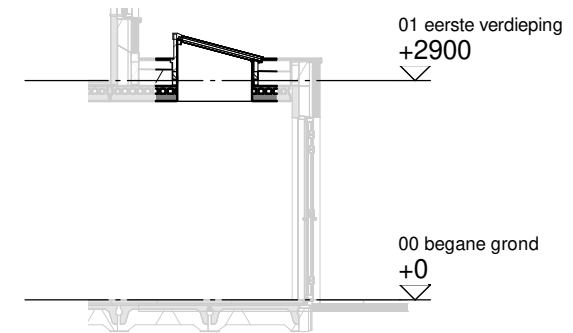
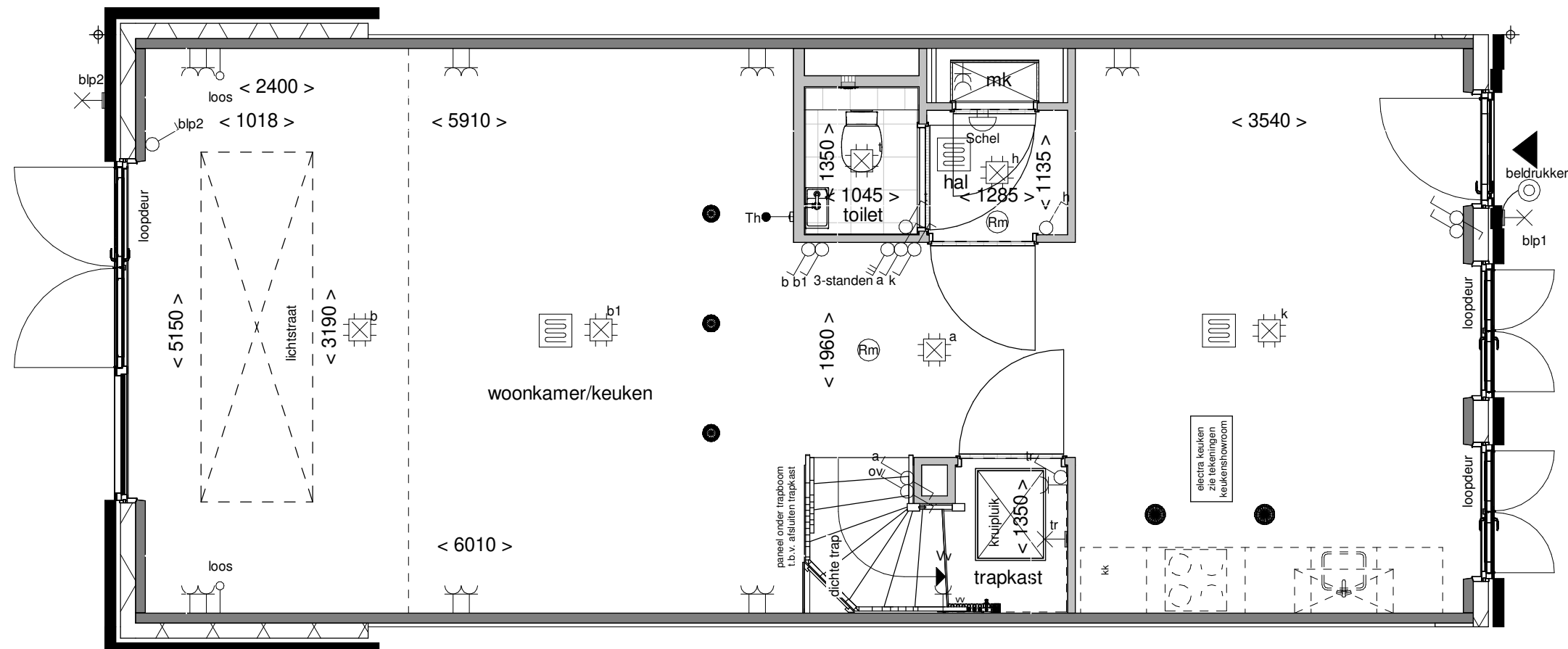

Doorsnede schaal 1:100

**ALLEMAAL  
VIELEYAAL**

Optie: Lichtstraat in uitbouw  
2400mm

Woningtype: X54

Bouwnummer: -

Optienummer: 1.B.X.14

Schaal: 1:50 / 1:100

Datum: 30-01-2024



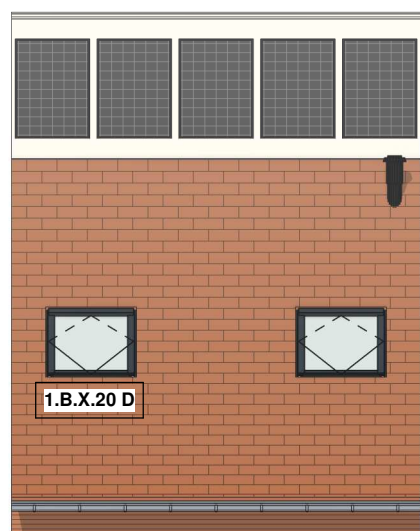
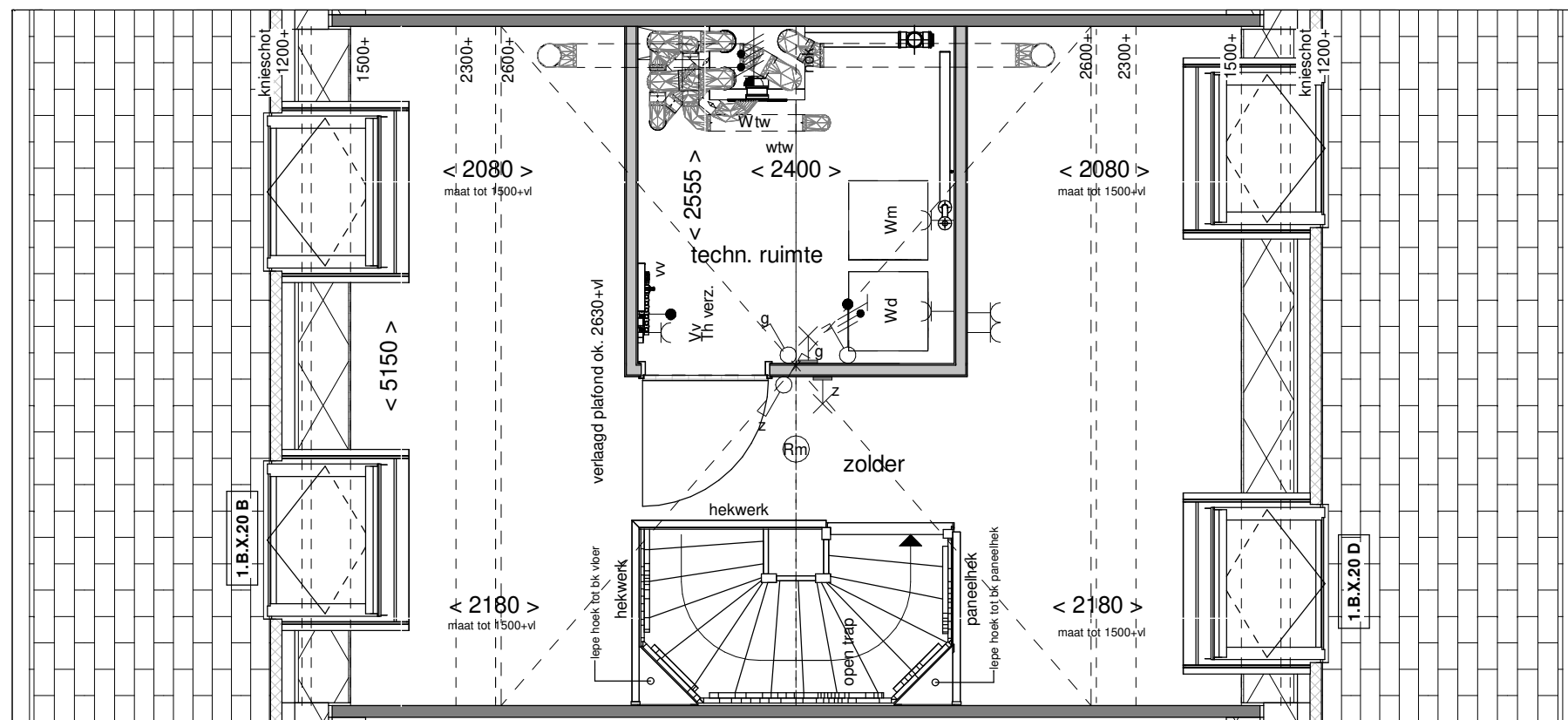

Voorgevel schaal 1:100

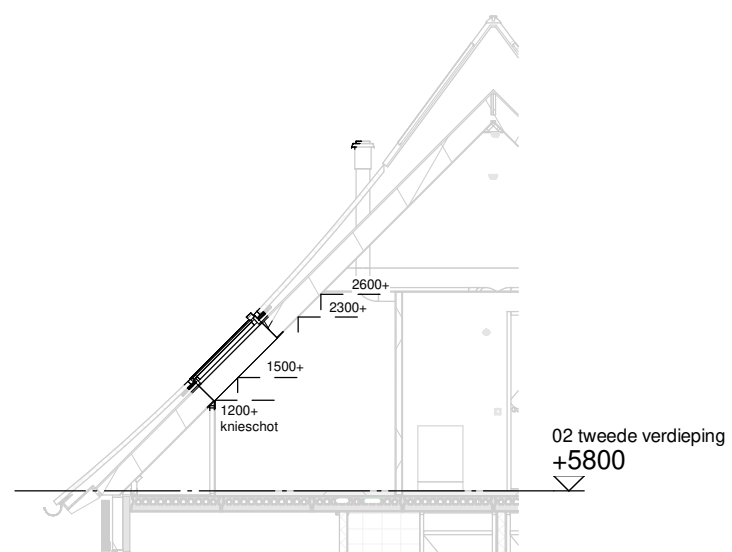

Doorsnede schaal 1:100

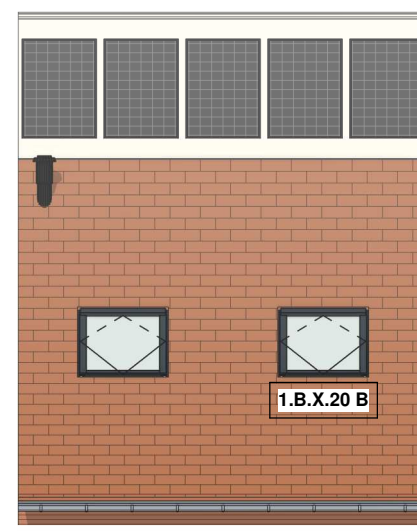

Achtergevel schaal 1:100

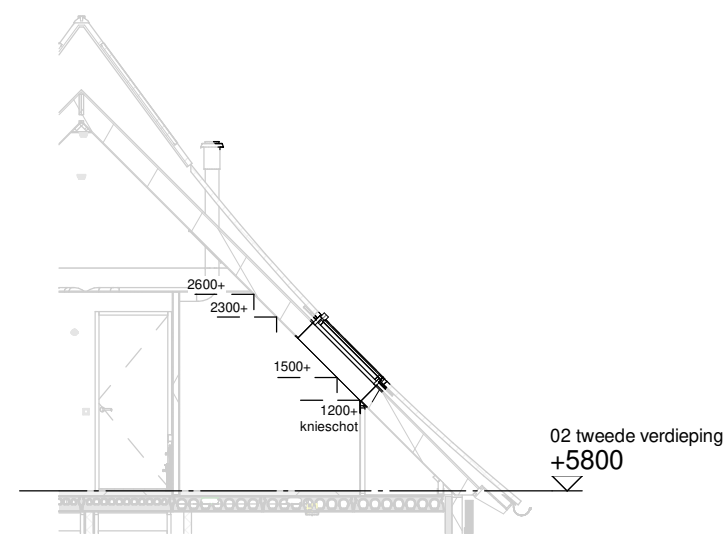

Doorsnede schaal 1:100

**ALLEMAAL  
YIELEYAAL**

Optie: Dakramen voor- en achtergevel

Woningtype: X54

Bouwnummer: -

Optienummer: 1.B.X.20

Schaal: 1:50 / 1:100

Datum: 30-01-2024

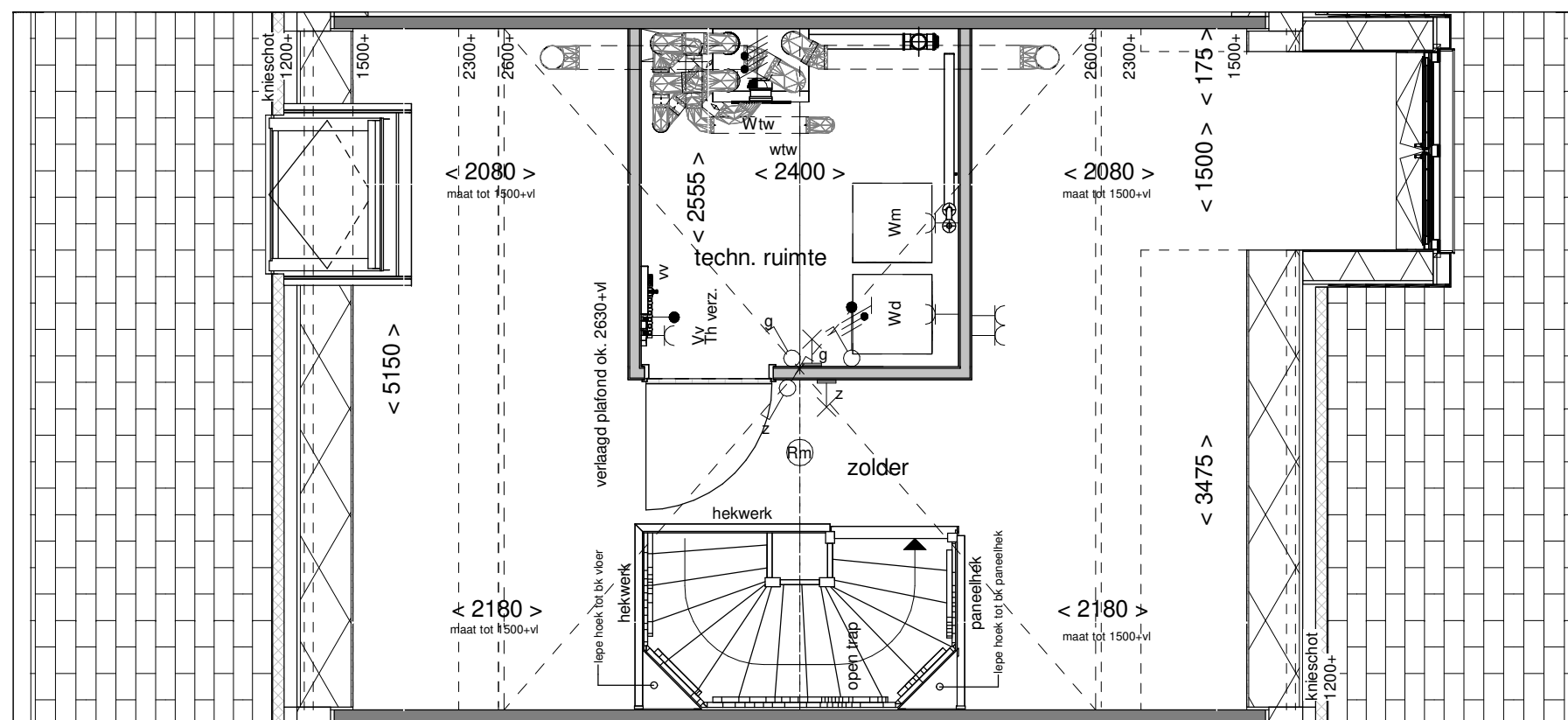

Voorgevel schaal 1:100

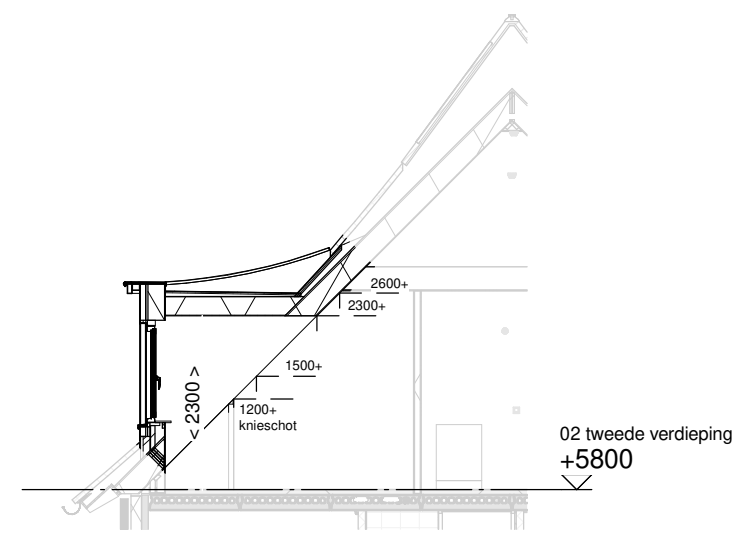

Doorsnede schaal 1:100

**ALLEMAAL  
VIELEYAAL**

Optie: Dakkapel  
voorgevel 1500mm

Woningtype: X54

Bouwnummer: -

Optienummer: 1.B.X.33

Schaal: 1:50 / 1:100

Datum: 30-01-2024

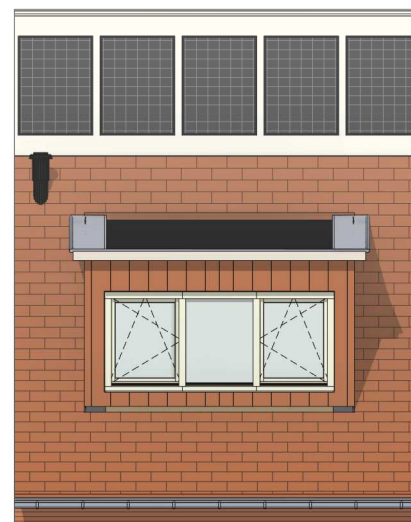
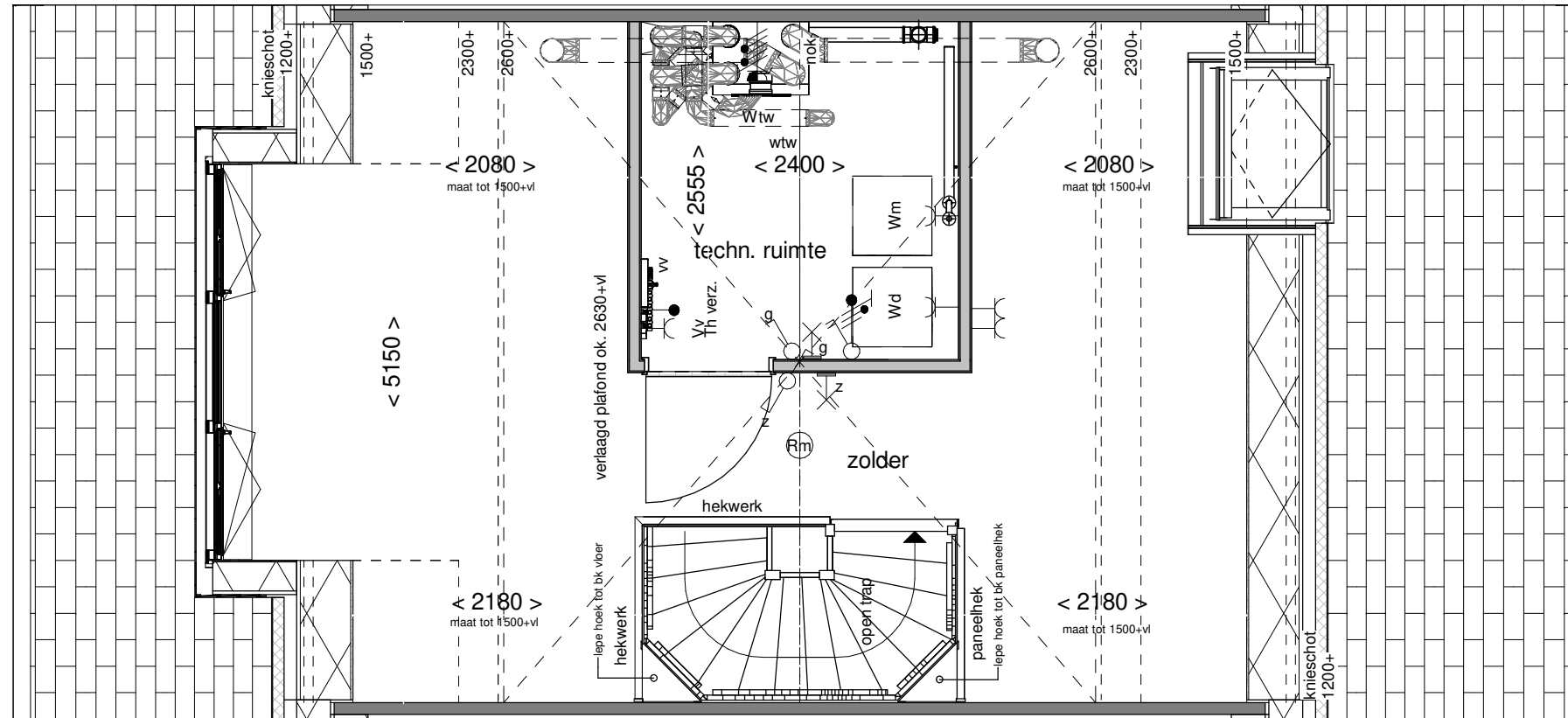

Achtergevel schaal 1:100

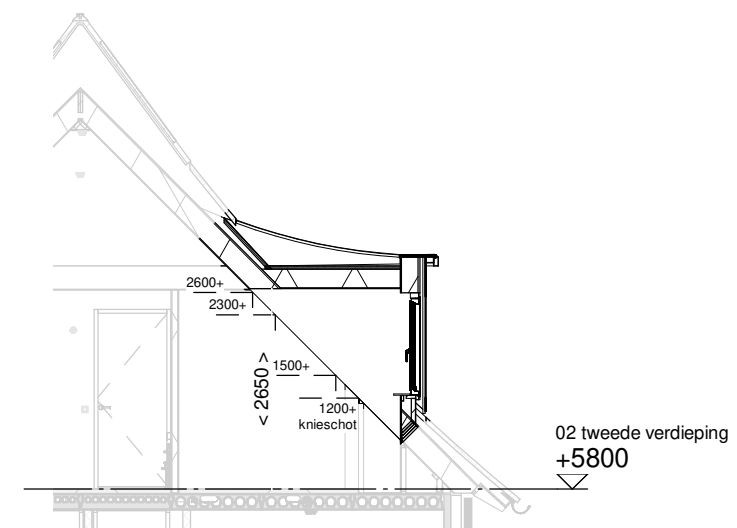

Doorsnede schaal 1:100

**ALLEMAAL  
YIELEYAAL**

Optie: Dakkapel  
achtergevel 3000mm

Woningtype: X54

Bouwnummer: -

Optienummer: 1.B.X.34

Schaal: 1:50 / 1:100

Datum: 30-01-2024

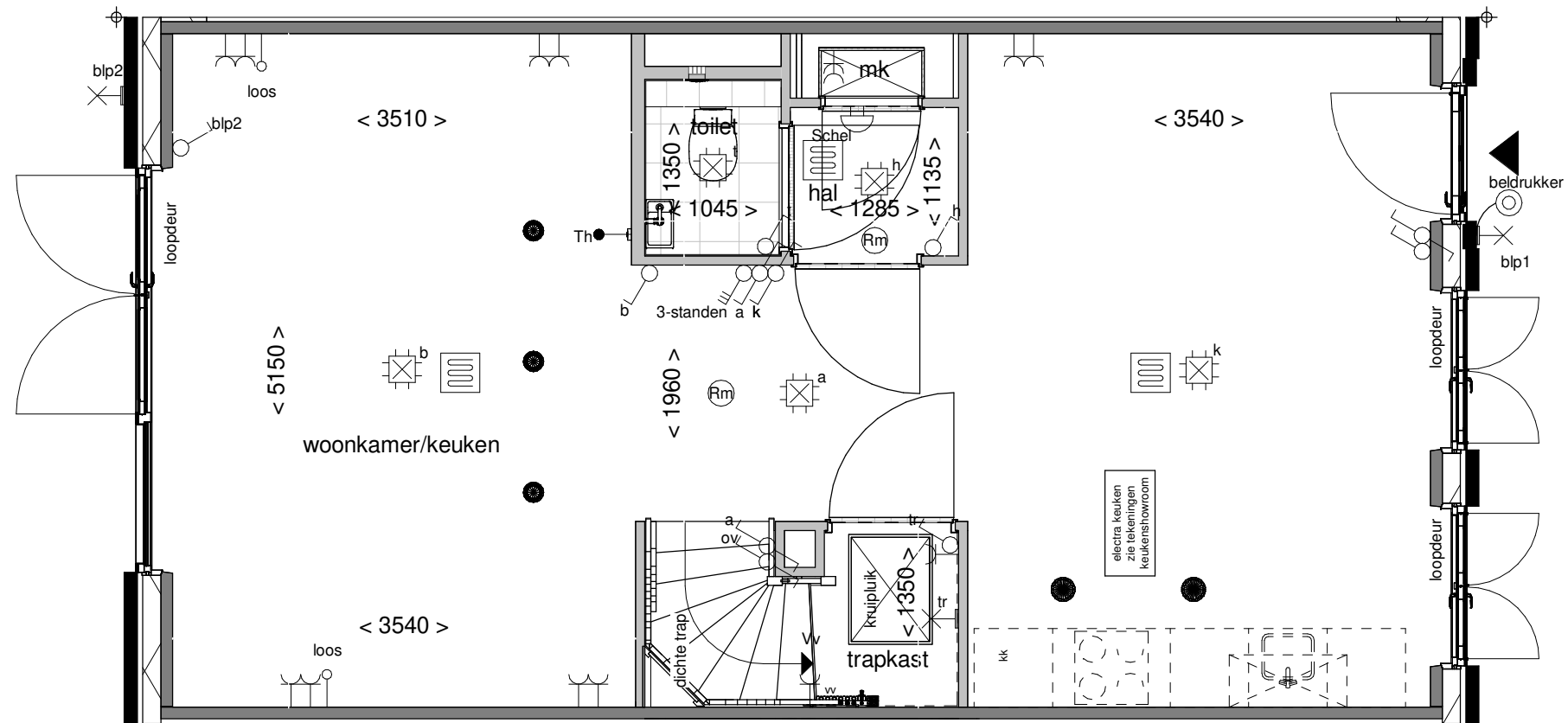

**ALLEMAAL  
VIELEYAAL**

Optie: **Wand naast trap**

Woningtype: **X54**

Bouwnummer: -

Optienummer: **1.C.X.10**

Schaal: **1:50**

Datum: **30-01-2024**

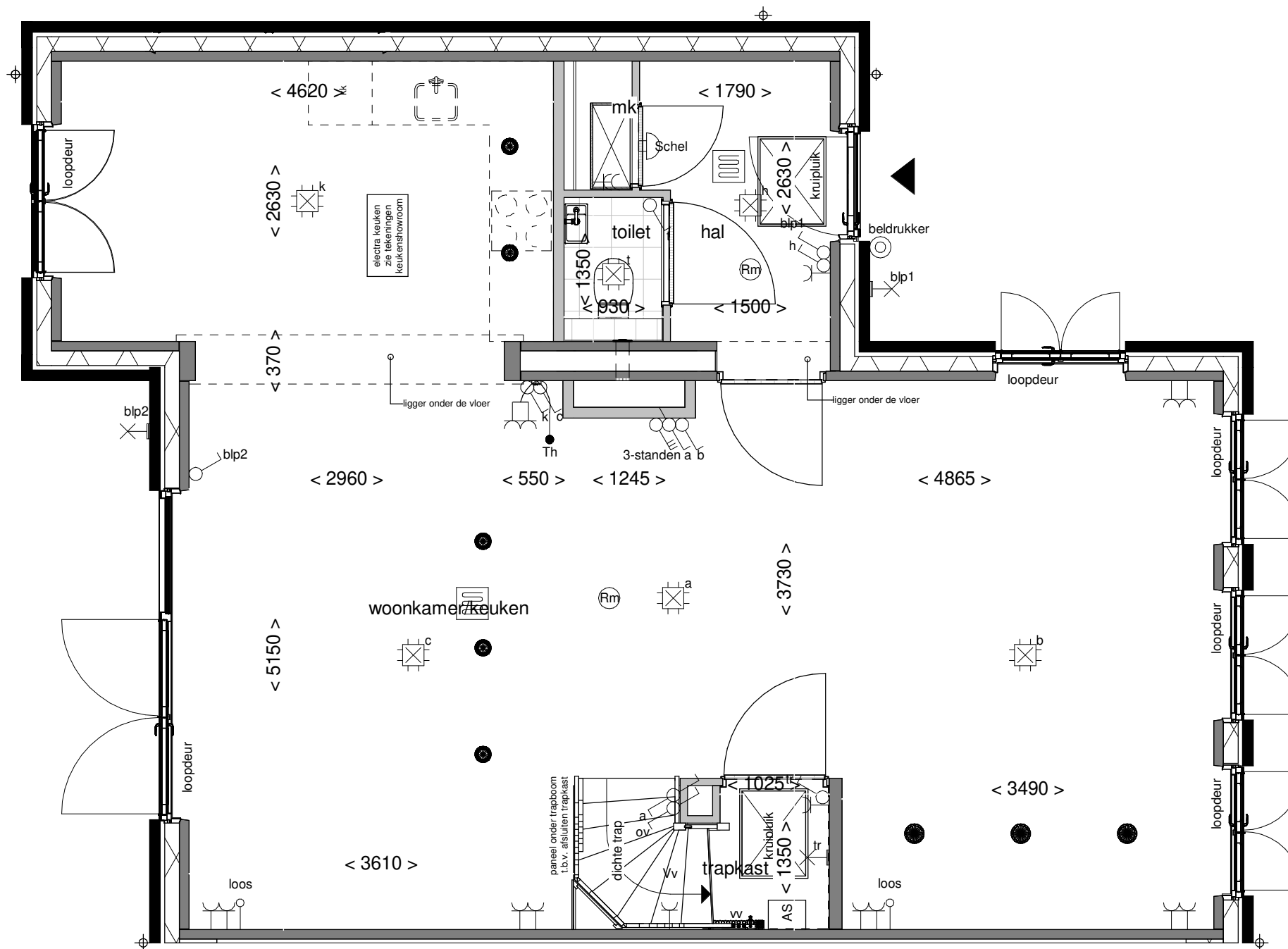

**ALLEMAAL  
VIELEVAAL**

Optie: Keuken in zij-uitbouw

Woningtype: X54U

Bouwnummer: -

Optienummer: 1.C.X.12

Schaal: 1:50

Datum: 30-01-2024

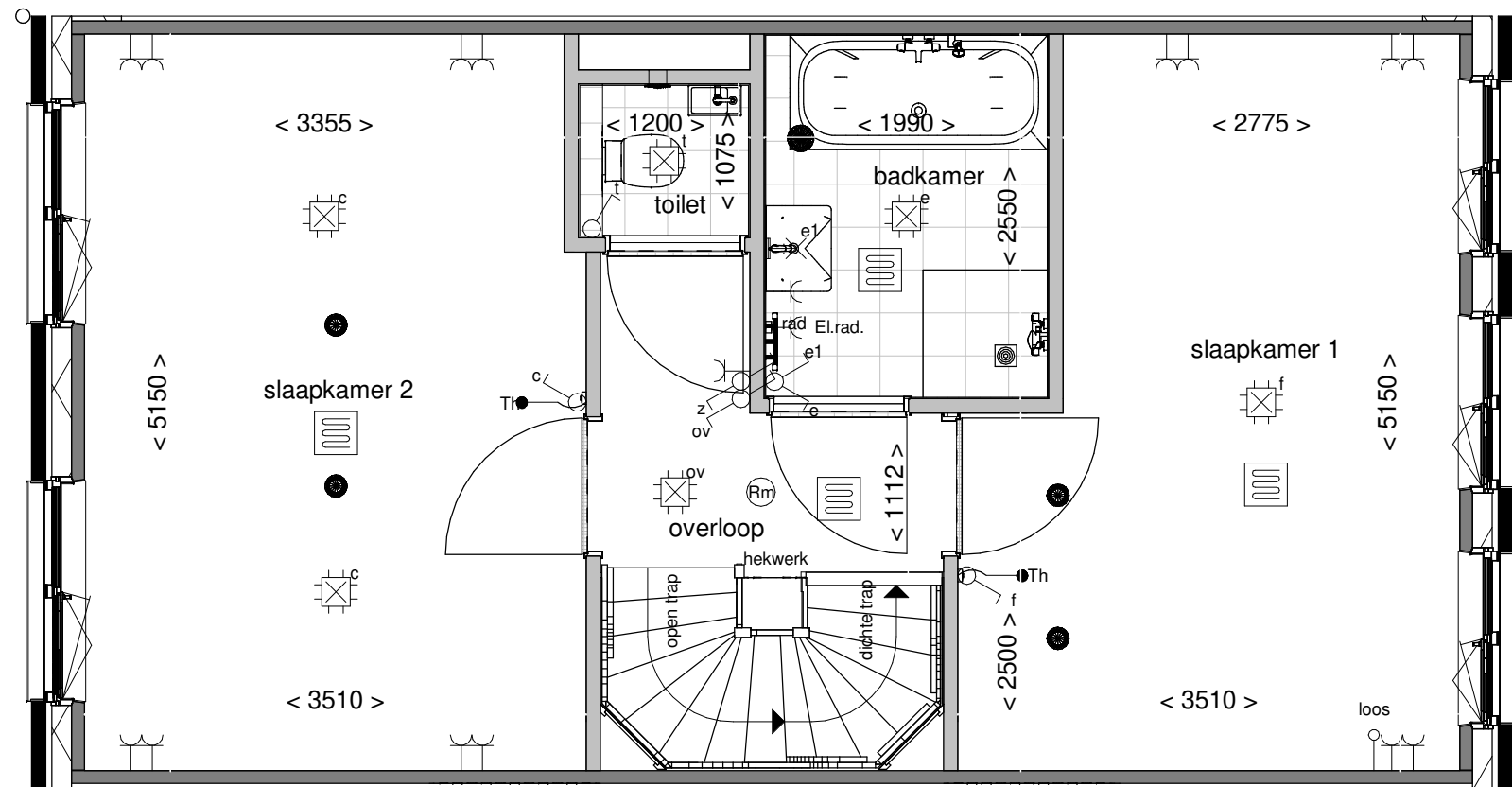

**ALLEMAAL  
VIELEYAAL**

Optie: Samenvoegen  
slaapkamer 2 en 3

Woningtype: X54

Bouwnummer: -

Optienummer: 1.C.X.30

Schaal: 1:50

Datum: 30-01-2024

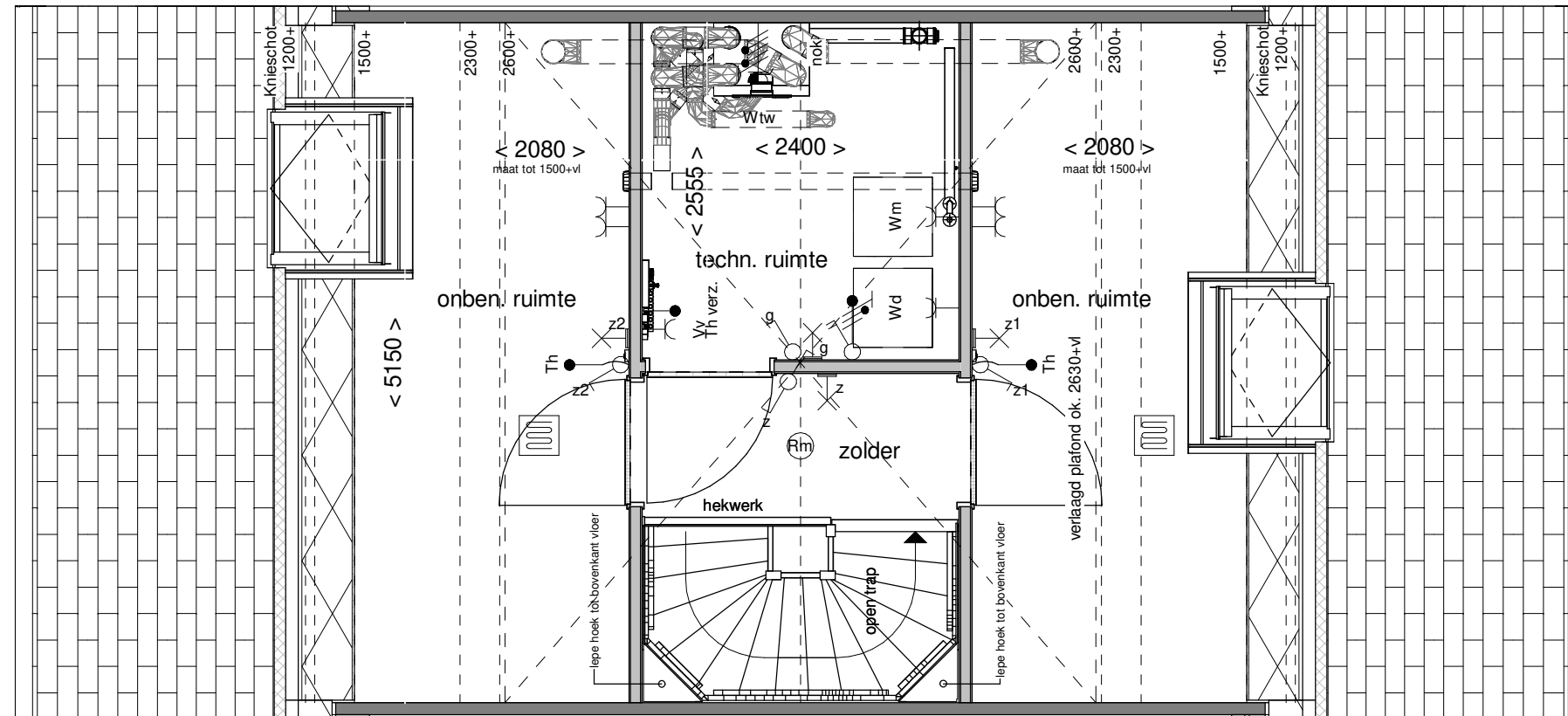

**ALLEMAAL  
VIELEYAAL**

Optie: Indeling techn.- en 2  
onb. ruimtes

Woningtype: X54

Bouwnummer: -

Optienummer: 1.C.X.76

Schaal: 1:50

Datum: 30-01-2024